



EVOPICV



Pettinaroli Pressure Independent Control Valves

PICV

Pressure Independent Control Valve

The **EvoPICV** Pressure Independent Control Valve "PICV" is a combined constant flow limiter and full stroke, full authority equal percentage temperature control valve.

The **EvoPICV** is suitable for use in variable and constant temperature systems and may be used as a constant flow limiter in constant volume systems (without an actuator head) or as a true PICV in variable volume systems.

OPERATING PRINCIPLES

EvoPICV valve is made up of three main parts:

1. differential pressure regulator
2. regulating valve for flow adjustment
3. flow pre-setting knob

DIFFERENTIAL PRESSURE REGULATOR

The differential pressure regulator is the heart of the pressure independent control valve. By keeping a constant differential pressure across the valve seats constant flow and full authority temperature control can be achieved.

Incoming pressure P1 is transmitted to the top face of the diaphragm, outgoing pressure P3 is transmitted to the underside of this same diaphragm. A constant effective differential pressure is maintained between P2 and P3. As P1 increases relative to P3 it acts on the diaphragm closing the shutter (A) against a seat (B) thereby lowering the effective differential pressure. As P1 decreases relative to P3 the diaphragm acts to open the shutter (A) from the seat (B) thus increasing the effective differential pressure. The diaphragm acts against a spring in order to balance the pressure control and stop the diaphragm oscillating.

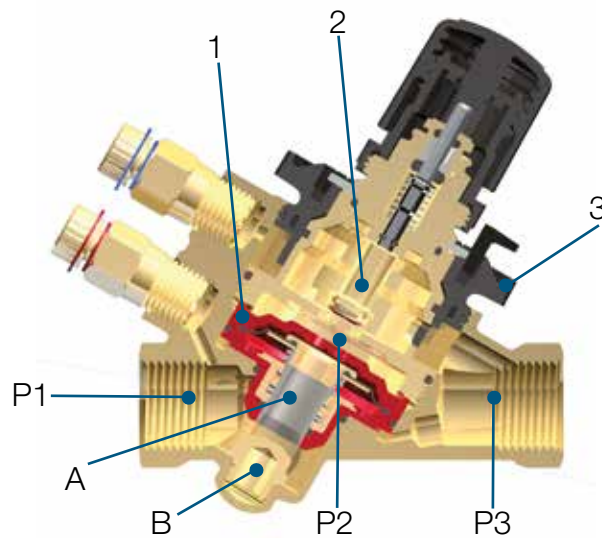

REGULATION VALVE

Water flow through a valve varies as a function of the area of passage and the pressure differential across that valve. Due to the incorporation of the differential pressure regulator the differential across the valve seats P2 – P3 is constant meaning that flow is now only a function of area of passage.

Setting any flow rate value and maintaining it is also possible. The regulation valve presents an equal percentage characteristic.

ADJUSTMENT KNOB

The maximum value of the flow can be preset, choking the outlet section of the control valve, using the graduated adjustment knob. The percentage value, indicated on the scale, matches the maximum flow rate percentage. This value can be changed turning the adjustment knob until it reaches the selected position (matching the percentage indicated on the scale). A locking mechanism stops the valve set values from being changed inadvertently.

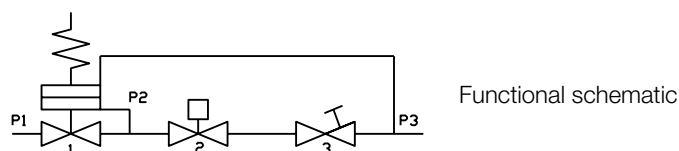

91 series 1/2" thru 1"



Pressure independent balancing and control valve with equal percentage characteristic. F x F connections.

PATENT
IT271811
EP 2488994
US8989140

General technical specifications

Accuracy 0 ÷ 1 bar	± 5%
ΔP max.	600 kPa / 6 bar
Temperature	-10 ÷ 120 °C
Working pressure max.	2500 kPa / 25 bar
Stroke	3 mm

	91VL 1/2"	91L 1/2"	91H 1/2"	91L 3/4"	91H 3/4"	91H 1"
Flow rate max.	150 l/h 0,042 l/s 0,66 GPM	600 l/h 0,167 l/s 2,64 GPM	780 l/h 0,217 l/s 3,43 GPM	1000 l/h 0,278 l/s 4,40 GPM	1500 l/h 0,417 l/s 6,60 GPM	1500 l/h 0,417 l/s 6,60 GPM
Start-up max.	20 kPa 0,20 bar 2,9 psi	25 kPa 0,25 bar 3,63 psi	35 kPa 0,35 bar 5,08 psi	30 kPa 0,30 bar 4,35 psi	35 kPa 0,35 bar 5,08 psi	35 kPa 0,35 bar 5,08 psi
Connections	Rp 1/2" F EN 10226-1 or NPT	Rp 1/2" F EN 10226-1 or NPT	Rp 1/2" F EN 10226-1 or NPT	Rp 3/4" F EN 10226-1 or NPT	Rp 3/4" F EN 10226-1 or NPT	Rp 1" F EN 10226-1 or NPT

MANUAL FLOW SETTING DEVICE



FLOW RATE

Flow rate can be adjusted without taking actuator off the valve.



AVAILABLE WITHOUT PRESSURE PORTS

91_1 and 91X series available without pressure port.



93 series 3/4" thru 1 1/4"

Pressure independent balancing and control valve with equal percentage characteristic. Union end connections F x F.



PATENT
IT271811
EP 2488994
US8989140

General technical specifications

Accuracy	0 ÷ 1 bar	± 5%
ΔP max.		600 kPa / 6 bar
Temperature		-10 ÷ 120 °C
Working pressure max.		2500 kPa / 25 bar
Stroke		6 mm

	93L 3/4"	93H 3/4"	93L 1"	93H 1"	93L 1 1/4"	93H 1 1/4"
Flow rate max.	2200 l/h 0,611 l/s 9,69 GPM	2700 l/h 0,750 l/s 11,89 GPM	2200 l/h 0,611 l/s 9,69 GPM	2700 l/h 0,750 l/s 11,89 GPM	2700 l/h 0,750 l/s 11,89 GPM	3000 l/h 0,833 l/s 13,21 GPM
Start-up max.	25 kPa 0,25 bar 3,63 psi	30 kPa 0,30 bar 4,35 psi	25 kPa 0,25 bar 3,63 psi	30 kPa 0,30 bar 4,35 psi	30 kPa 0,30 bar 4,35 psi	35 kPa 0,35 bar 5,08 psi
Connections	Rc 3/4" union F EN 10226-1 or NPT	Rc 3/4" union F EN 10226-1 or NPT	Rc 1" union F EN 10226-1 or NPT	Rc 1" union F EN 10226-1 or NPT	Rc 1 1/4" union F EN 10226-1 or NPT	Rc 1 1/4" union F EN 10226-1 or NPT

REMOVABLE DIAPHRAGM

Removable diaphragm for flushing, maintenance and trouble shooting



DIAPHRAGM

Diaphragm made in one solid piece, resulting in easier handling and maintenance.

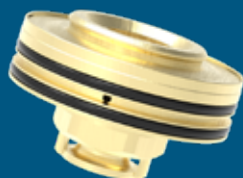

AVAILABLE WITHOUT PRESSURE PORTS

93_1 series available without pressure port.



83 series 1 1/4" thru 2"



Pressure independent balancing and control valve for rotary actuator.
With Presetting device. Union end connections F x F.

PATENT
EP 2.841.853.B1
US9383033B2
IT277258

General technical specifications

Accuracy 0 ÷ 1 bar	± 5%
ΔP max.	600 kPa / 6 bar
Temperature	-10 ÷ 120 °C
Working pressure max.	1600 kPa / 16 bar
Stroke	90°

	83HPR1 1 1/4"	83LPR1 1 1/2"	83HPR1 1 1/2"	83VLPR1 2"	83LPR1 2"	83HPR1 2"
Flow rate max.	6000 l/h 1,67 l/s 26,42 GPM	6000 l/h 1,67 l/s 26,42 GPM	9000 l/h 2,50 l/s 39,63 GPM	11000 l/h 3,06 l/s 48,43 GPM	12000 l/h 3,33 l/s 52,83 GPM	18000 l/h 5,00 l/s 79,25 GPM
Start-up max.	30 kPa 0,30 bar 4,35 psi	30 kPa 0,30 bar 4,35 psi	35 kPa 0,35 bar 5,08 psi	40 kPa 0,40 bar 5,80 psi	35 kPa 0,35 bar 5,08 psi	35 kPa 0,35 bar 5,08 psi
Connections	Rc 1 1/4" union F EN 10226-1 or NPT	Rc 1 1/2" union F EN 10226-1 or NPT	Rc 1 1/2" union F EN 10226-1 or NPT	Rc 2" union F EN 10226-1 or NPT	Rc 2" union F EN 10226-1 or NPT	Rc 2" union F EN 10226-1 or NPT

INTEGRATED FLUSHING MODE

OPERATION MODE

Control valve fully open, controlling the flow through profiled ball and a 90° rotating actuator.

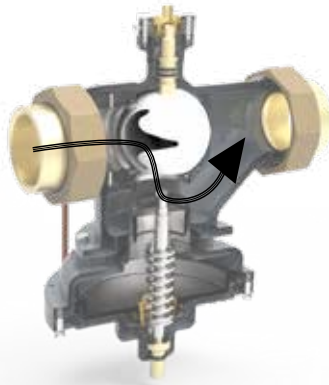

FLUSHING MODE

Control valve rotated by 180°, profiled opening outside flow path. The valve has now full port passage, allowing twice maximum flow, for proper flushing and cleaning.

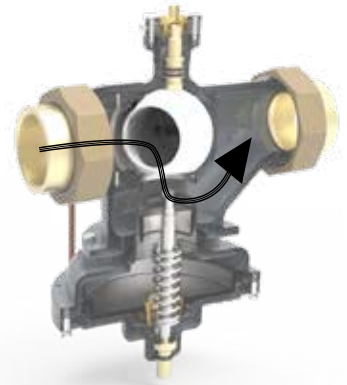

MANUAL FLOW SETTING DEVICE



CHARACTERIZED PROFILE

Solid and reliable characterized control ball valve. Full port profile.



94F series 2" thru 10"



Pressure independent balancing and control valve.
 Selectable linear or equal percentage control characteristic.
 Ductile Iron body.
 Flanged connections.
 SMART actuator included.

General technical specifications

Accuracy 0 ÷ 1 bar	± 5%
ΔP max. 2" - 6"	600 kPa / 6 bar
ΔP max. 8" - 10"	400 kPa / 4 bar
Temperature	-10 ÷ 120 °C
Working pressure max.	1600 kPa / 16 bar

	94FH 2"	94FL 2 1/2"	94FH 2 1/2"	94FL 3"	94FL 4"	94FL 5"	94FH 5"
Flow rate max.	20000 l/h 5,56 l/s 88,06 GPM	20000 l/h 5,56 l/s 88,06 GPM	30000 l/h 8,30 l/s 132,09 GPM	30000 l/h 8,30 l/s 132,09 GPM	55000 l/h 15,28 l/s 242,16 GPM	90000 l/h 25,00 l/s 396,26 GPM	120000 l/h 33,33 l/s 528,34 GPM
Start-up max.	40 kPa 0,40 bar 5,80 psi	40 kPa 0,40 bar 5,80 psi	30 kPa 0,30 bar 4,35 psi	30 kPa 0,30 bar 4,35 psi	30 kPa 0,30 bar 4,35 psi	35 kPa 0,35 bar 5,08 psi	35 kPa 0,35 bar 5,08 psi
Connections	Flanged EN 1092-2	Flanged EN 1092-2	Flanged EN 1092-2	Flanged EN 1092-2	Flanged EN 1092-2	Flanged EN 1092-2	Flanged EN 1092-2

	94FL 6"	94FH 6"	94FL 8"	94FH 8"	94FL 10"	94FH 10"
Flow rate max.	90000 l/h 25,00 l/s 396,26 GPM	150000 l/h 41,667 l/s 660,43 GPM	200000 l/h 55,556 l/s 880,57 GPM	300000 l/h 83,333 l/s 1320,86 GPM	300000 l/h 83,333 l/s 1320,86 GPM	500000 l/h 138,889 l/s 2201,43 GPM
Start-up max.	35 kPa 0,35 bar 5,08 psi	50 kPa 0,50 bar 7,50 psi	40 kPa 0,40 bar 5,80 psi	40 kPa 0,40 bar 5,80 psi	40 kPa 0,40 bar 5,80 psi	65 kPa 0,65 bar 9,43 psi
Connections	Flanged EN 1092-2	Flanged EN 1092-2	Flanged EN 1092-2	Flanged EN 1092-2	Flanged EN 1092-2	Flanged EN 1092-2

95F series available with connection ANSI B16.42 EN 558 (face to face)

SMART ACTUATOR

Flow rate can be easily set from the on-board user interface.
 Compatible with most used control signals:
Proportional (current or voltage control)
 3 point floating
 ON/OFF
 0(2) - 10 V , 0(4) – 20 mA position feedback signal for a total remote management.
 Manual override
 Fail safe with optional battery



THERMO ELECTRIC ACTUATOR



Code	Volt	Stroke	For valves series	Notes
A54202	230V	4 mm	91	with adapter VA64
A54204	230V	4 mm	91	with adapter VA64. With micro switch aux. 4 wires
A54402	24V	4 mm	91	with adapter VA64
A54404	24V	4 mm	91	with adapter VA64. With micro switch aux. 4 wires
A55102	120V	5 mm	91	with adapter VA64
A56102	120V	6,5 mm	93	with adapter VA64
A56202	230V	6,5 mm	93	with adapter VA64
A56402	24V	6,5 mm	93	with adapter VA64

Code	Volt	Stroke	For valves series	Notes
A544P3	0-10V	4 mm	91	Proportional version with adapter VA64
A564P3	0-10V	6,5 mm	93	Proportional version with adapter VA64

ELECTROMOTIVE ACTUATOR



Code	Volt	Stroke	For valves series	Notes
VA7481	24V	6,3 mm	91 / 93	Floating version. Adaptor not included. Art. 0A7010 for 91 series. Art. 0A748X for 93 series
VA7481	230V	6,3 mm	91 / 93	Floating version. Adaptor not included. Art. 0A7010 for 91 series. Art. 0A748X for 93 series
VA7482	0-10V	6,3 / 3,2 mm	91 / 93	Proportional version. Adaptor not included. Art. 0A7010 for 91 series. Art. 0A748X for 93 series

Code	Volt	Stroke	For valves series	Notes
VM060	0-10V	6,5 mm	91 / 93	Manual override, valve stroke detection system, failsafe return system, feedback signal options. Adaptor included.
VM000	0-10V	6,5 mm	91 / 93	Manual override, valve stroke detection system, feedback signal options. Adaptor included.

Code	Volt	Rotation	For valves series	Notes
SN08	24V	0° - 90°	81 / 83	Electromotive actuator, floating control; linkage bracket included. 8 Nm operating torque.
SN08	230-110V	0° - 90°	81 / 83	Electromotive actuator, floating control; linkage bracket included. 8 Nm operating torque.
SN08CC	24 V - (0-10V)	0° - 90°	81 / 83	Electromotive actuator, floating control; linkage bracket included. 8 Nm operating torque.

Code	Volt	Rotation	For valves series	Notes
VA9208	24V	0° - 95°	83	Electromotive actuator. On/Off control. Spring return option.
VA9208	230V	0° - 95°	83	Electromotive actuator. On/Off control. Spring return option.
VA9208C	24 V - (0-10V)	0° - 95°	83	Electromotive actuator. Proportional control. Spring return option.

PETTINAROLI GROUP



Jomar Group
Warren - USA

Hydronic Components HCI
Warren - USA



Pettinaroli Denmark
Middelfart - DEN

Pettinaroli UK - Marflow Hydraulics
Birmingham - UK

TSM Galvanocromo
Gozzano - ITA

FRATELLI PETTINAROLI
S.Maurizio d'Opaglio - ITA

Pettinaroli Suisse
Montreux - SUI

Pettinaroli France
Carmaux - FRA



Pettinaroli Middle East
Dubai - UAE