

# 91 / 91-1



## EN Description

The pressure independent control valve (PICV) combines the functions of a differential pressure controller, regulation valve and 2 port control valve into a single body.

The EVOPICV incorporates a small diaphragm type DPCV in order to keep a constant differential pressure across an orifice and to provide a constant flow rate whilst the differential pressure is within the operating limits of the valve. Beyond these working pressures the valve acts as a fixed orifice.

Making this orifice adjustable allows the valve to be pre-set to deliver a range of flow rates. In the case of the EVOPICV valve this adjustment can be made in situ without removing any covers or actuators, the adjustment wheel is lockable by means of a combined memory stop and indicator.

The EVOPICV valve also includes 2 port temperature control by means of an oblique pattern globe valve. The plug of the globe valve is machined to give a near equi-percentage flow control characteristic. Due to the fact that the differential pressure across the valve seat is constant it can be said that the authority of this control valve is very close to 1.

Due to the way the EVOPICV valve controls the flow rate, irrespective of differential pressure branch and sub mains, balancing valves are not required. The flow rate is maintained at the terminal unit regardless of system conditions making the valve ideal for systems with inverter driven pumps.

Valves of the 91-1 series have not the pressure ports: this is the only difference to 91 series.

## EN Valve features

The 91 series PICV valve offers the following functions:

- Good valve authority to maintain temperature control and power output from the terminal unit using the complete stroke of the valve.
- Maximum design flow limitation: once set, the 91 valve maintains design flow regardless of pressure changes in the system.
- it can easily be set up once installed, using the external setting ring.
- Measure by means of specific meter of the differential pressure across the valve: in this way user can verify if the start-up pressure has been reached and overpassed. **Not available on 91-1.**

ΔP max.	Close off pressure *	Temperature	Working pressure max.	Stroke	Rangeability	Leakage	Accuracy 0 ÷ 1 bar**
600 kPa / 6 bar	600 kPa / 6 bar	-10 ÷ 120 °C	2500 kPa / 25 bar	3 mm	50÷100 IEC 60534-2-3	Class IV IEC 60534-4	± 5%

	91VL 1/2"	91L 1/2"	91H 1/2"	91L 3/4"	91H 3/4"	91H 1"
	91VL1 1/2"	91L1 1/2"	91H1 1/2"	91L1 3/4"	91H1 3/4"	91H1 1"
<b>Flow rate max.</b>	150 l/h 0,042 l/s	600 l/h 0,167 l/s	780 l/h 0,217 l/s	1000 l/h 0,278 l/s	1500 l/h 0,417 l/s	1500 l/h 0,417 l/s
<b>Start-up max.</b>	20 kPa 0,20 bar	25 kPa 0,25 bar	35 kPa 0,35 bar	30 kPa 0,30 bar	35 kPa 0,35 bar	35 kPa 0,35 bar
<b>Connections</b>	Rp 1/2" F EN 10226-1	Rp 1/2" F EN 10226-1	Rp 1/2" F EN 10226-1	Rp 3/4" F EN 10226-1	Rp 3/4" F EN 10226-1	Rp 1" F EN 10226-1

\* Closed by actuator

\*\* at 100%. For other presetting and differential pressure, refer to "Flow setting accuracy" on the PICV manual.



EN Dimensional data

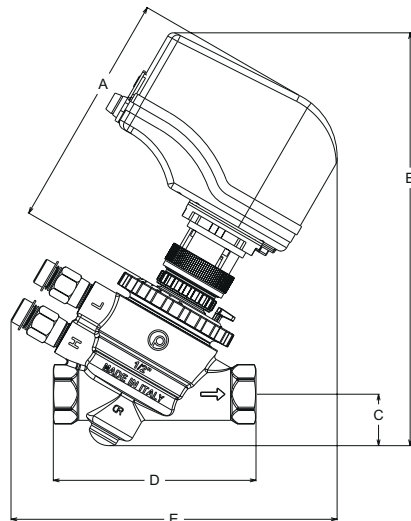
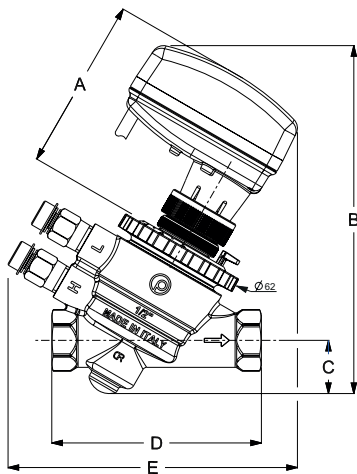
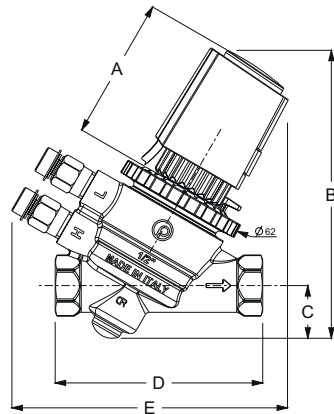
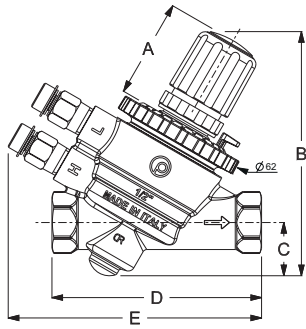

Manual valve						
Art.	Flow rate [l/h]	A (mm)	B (mm)	C (mm)	D (mm)	E (mm)
91VL 1/2"	150	47	115	25	99	120
91L 1/2"	600	47	115	25	99	120
91H 1/2"	780	47	115	25	99	120
91L 3/4"	1000	47	115	25	108	127
91H 3/4"	1500	47	115	25	108	127
91H 1"	1500	47	115	25	130	134

Valve with thermo-electric actuator						
Art.	Flow rate [l/h]	A (mm)	B (mm)	C (mm)	D (mm)	E (mm)
91VL 1/2"	150	68	137,5	25	99	127
91L 1/2"	600	68	137,5	25	99	127
91H 1/2"	780	68	137,5	25	99	127
91L 3/4"	1000	68	137,5	25	108	127
91H 3/4"	1500	68	137,5	25	108	127
91H 1"	1500	68	137,5	25	130	134

Valve with electromotive actuator						
Art.	Flow rate [l/h]	A (mm)	B (mm)	C (mm)	D (mm)	E (mm)
91VL 1/2"	150	82	164	25	99	137
91L 1/2"	600	82	164	25	99	137
91H 1/2"	780	82	164	25	99	137
91L 3/4"	1000	82	164	25	108	137
91H 3/4"	1500	82	164	25	108	137
91H 1"	1500	82	164	25	130	138

Valve with VM060						
Art.	Flow rate [l/h]	A (mm)	B (mm)	C (mm)	D (mm)	E (mm)
91VL 1/2"	150	116	201	25	99	159
91L 1/2"	600	116	201	25	99	159
91H 1/2"	780	116	201	25	99	159
91L 3/4"	1000	116	201	25	108	166
91H 3/4"	1500	116	201	25	108	166
91H 1"	1500	116	201	25	130	173



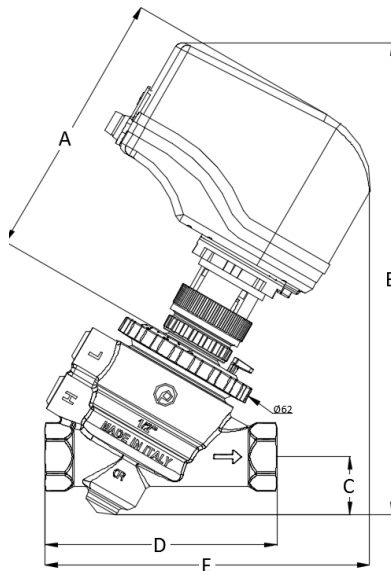
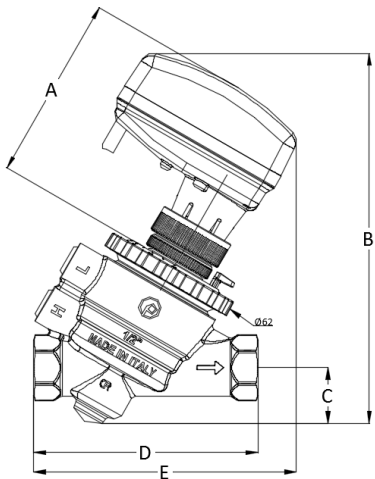
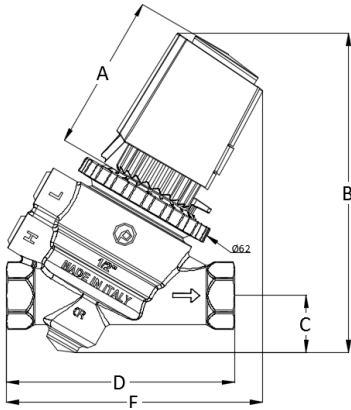
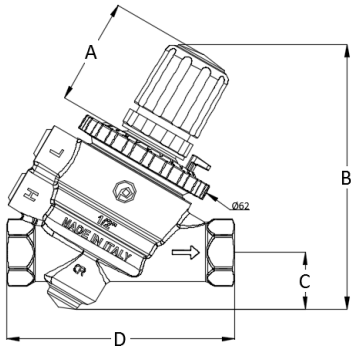

Manual valve					
Art.	Flow rate [l/h]	A (mm)	B (mm)	C (mm)	D (mm)
91VL1 1/2"	150	68	137,5	25	99
91L1 1/2"	600	68	137,5	25	99
91H1 1/2"	780	68	137,5	25	99
91L1 3/4"	1000	68	137,5	25	108
91H1 3/4"	1500	68	137,5	25	108
91H1 1"	1500	68	137,5	25	130

Valve with thermo-electric actuator						
Art.	Flow rate [l/h]	A (mm)	B (mm)	C (mm)	D (mm)	E (mm)
91VL1 1/2"	150	68	137,5	25	99	111
91L1 1/2"	600	68	137,5	25	99	111
91H1 1/2"	780	68	137,5	25	99	111
91L1 3/4"	1000	68	137,5	25	108	111
91H1 3/4"	1500	68	137,5	25	108	111
91H1 1"	1500	68	137,5	25	130	129

Valve with electromotive actuator						
Art.	Flow rate [l/h]	A (mm)	B (mm)	C (mm)	D (mm)	E (mm)
91VL1 1/2"	150	82	164	25	99	116
91L1 1/2"	600	82	164	25	99	116
91H1 1/2"	780	82	164	25	99	116
91L1 3/4"	1000	82	164	25	108	116
91H1 3/4"	1500	82	164	25	108	116
91H1 1"	1500	82	164	25	130	134

Valve with VM060						
Art.	Flow rate [l/h]	A (mm)	B (mm)	C (mm)	D (mm)	E (mm)
91VL1 1/2"	150	116	201	25	99	139
91L1 1/2"	600	116	201	25	99	139
91H1 1/2"	780	116	201	25	99	139
91L1 3/4"	1000	116	201	25	108	141
91H1 3/4"	1500	116	201	25	108	141
91H1 1"	1500	116	201	25	130	156



**EN Materials and weight**

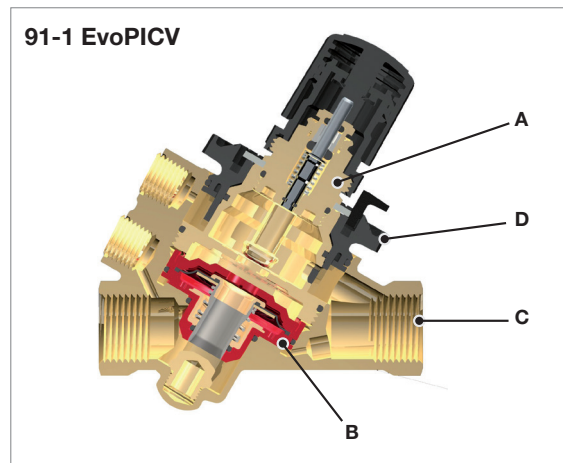
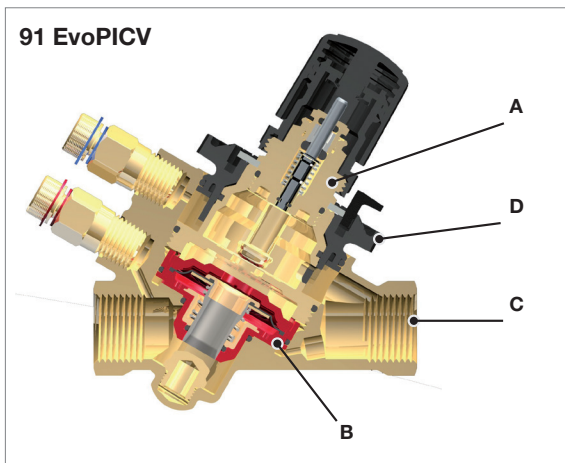

Material list	
<b>Regulating valve (A)</b>	Brass CW614N Stainless steel 18/8
<b>Diaphragm (B)</b>	High resistance polymer - EPDM Stainless steel AISI 303
<b>Presetting (D)</b>	High resistance polymer Brass CW614N
<b>Body (C)</b>	Corrosion resistant brass CW602N
<b>Gaskets</b>	EPDM-x

Art.	Weight (kg)
<b>91VL 1/2"</b>	0,88
<b>91L 1/2"</b>	0,88
<b>91H 1/2"</b>	0,88
<b>91L 3/4"</b>	0,95
<b>91H 3/4"</b>	0,95
<b>91H 1"</b>	1,05

Art.	Weight (kg)
<b>91VL1 1/2"</b>	0,84
<b>91L1 1/2"</b>	0,84
<b>91H1 1/2"</b>	0,84
<b>91L1 3/4"</b>	0,91
<b>91H1 3/4"</b>	0,91
<b>91H1 1"</b>	1,01

**EN Installation and maintenance EvoPICV 91 and 91-1**

**1. Use conditions**

The valve has to be mounted with the arrow in the direction of the flow. Mounting it in the wrong direction may damage the system and the valve itself.

If flow reversal is possible, a non-return valve should be mounted.

Minimum differential pressure above which the valve begins to exercise its regulating effect:

	<b>91VL 1/2"</b>	<b>91L 1/2"</b>	<b>91H 1/2"</b>	<b>91L 3/4"</b>	<b>91H 3/4"</b>	<b>91H 1"</b>
	<b>91VL1 1/2"</b>	<b>91L1 1/2"</b>	<b>91H1 1/2"</b>	<b>91L1 3/4"</b>	<b>91H1 3/4"</b>	<b>91H1 1"</b>
<b>ΔP Start-up</b>	20 kPa 0,20 bar	25 kPa 0,25 bar	35 kPa 0,35 bar	30 kPa 0,30 bar	35 kPa 0,35 bar	35 kPa 0,35 bar

Medium
Water / Water+glycol 30%

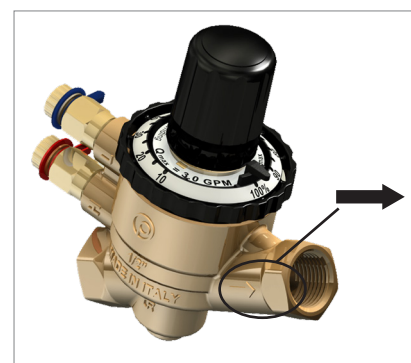

**2. Flow preset**

To set the selected flow, follow these steps:

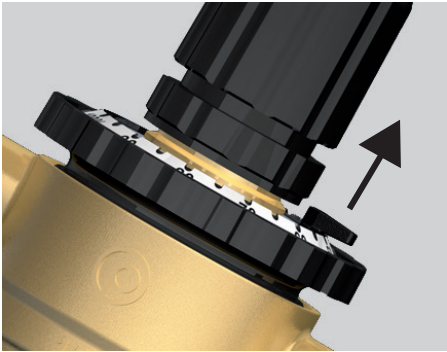

Lift the lock pin to unlock the selector

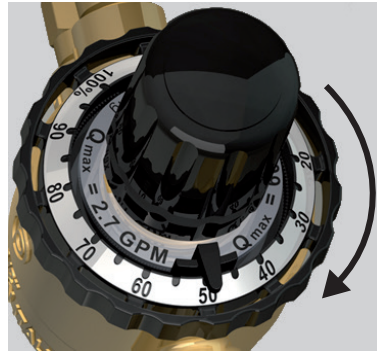

Turn the selector to the target position

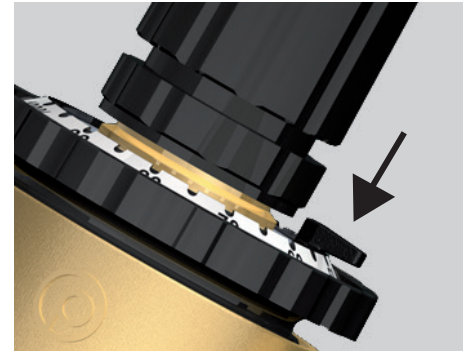

Press the lock pin to lock the selector in the final position

**3. Operating control**

It is necessary to be sure that the valve is actually working in the operating range. In order to verify it, just measure the differential pressure across the valve, as shown in the picture.

If the measured differential pressure is higher than the start-up pressure, the valve is actually keeping the flow constant at the set value.

Pettinaroli MDPS2 is the device which allows to do it: along with a smartphone and the dedicated app, it can directly give the user the differential pressure compared to the start-up differential pressure of the valve (proper valve has to be selected among all the Pettinaroli EvoPICV catalogue).

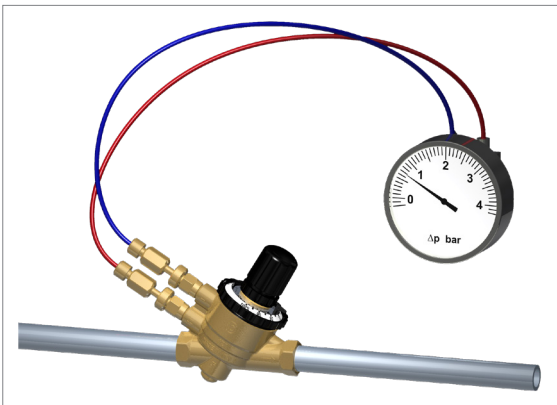

**4. Maintenance and cleaning**

During valve cleaning operations, use a damp cloth. DO NOT use any detergent or chemical product that may seriously damage or compromise the proper functioning and the reliability of the valve.

**5. Actuator assembly**

The valve can be equipped with a series of thermal-electric or electro-mechanical actuators, according to the requirements of the system. Actuators come along with an adaptor for proper mounting on the valve and for proper functioning of the whole device.

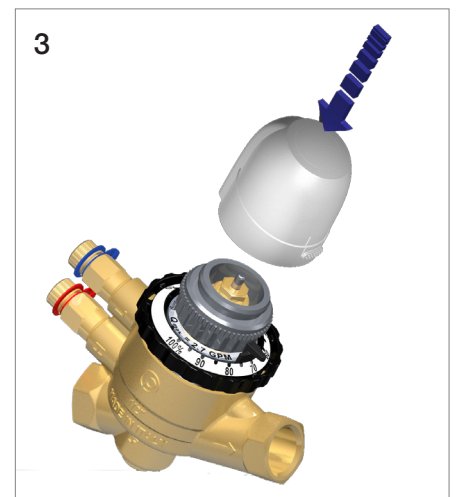
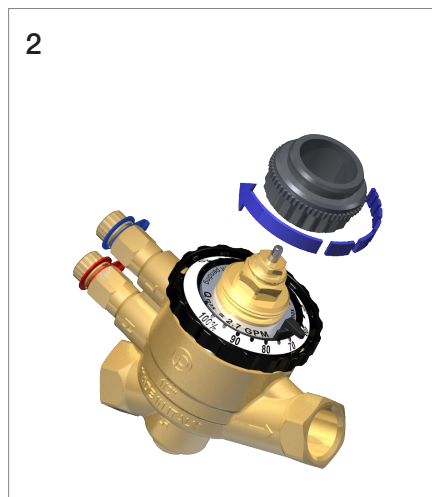
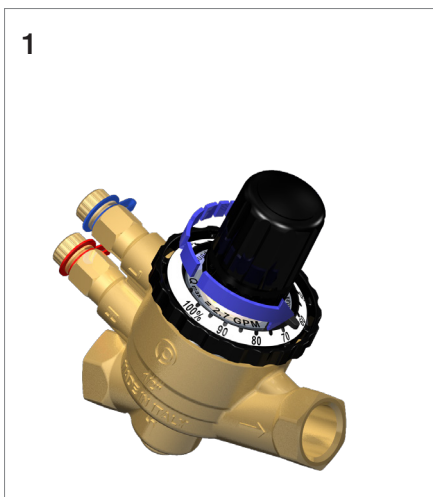

6. Replacement of the diaphragm of EVOPICV valve - 091SET maintenance kit

For further information please refer to instruction 208 - 091SET

091SET maintenance kit

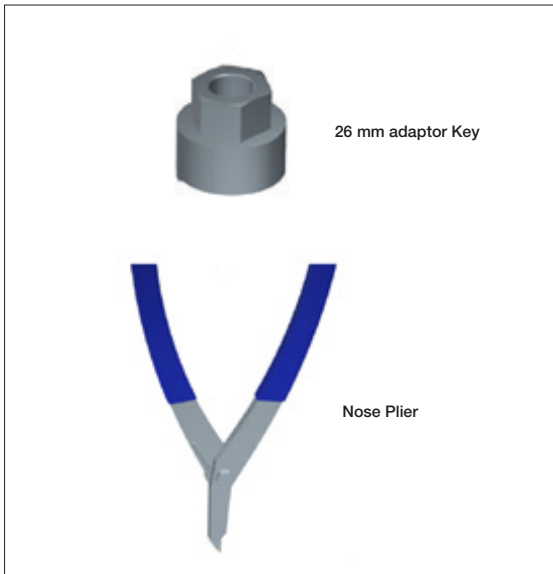

Step 1: remove completely the knob

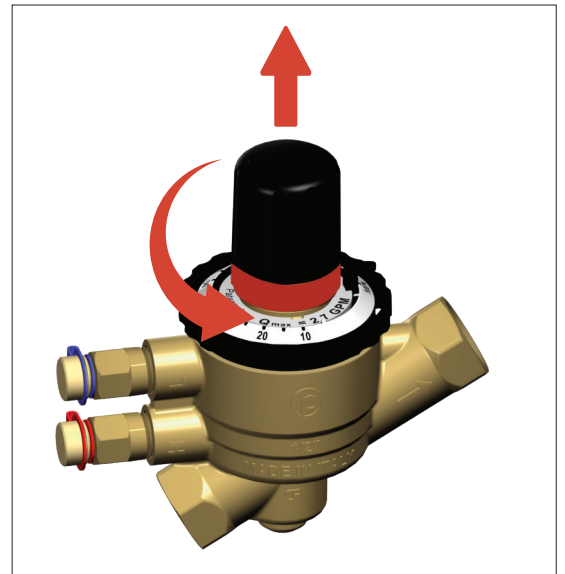

Step 1a: remove the actuator and the adapter.

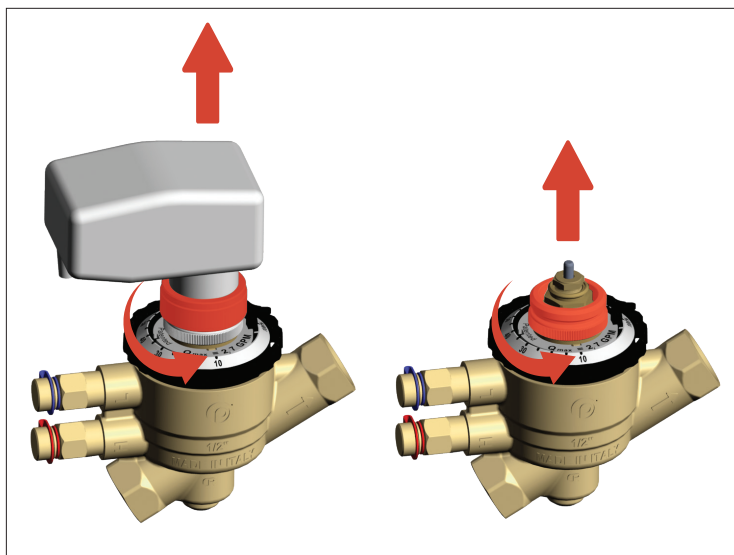

Step 2: using the 26mm adaptor key provided to remove the headwork. Align latches.

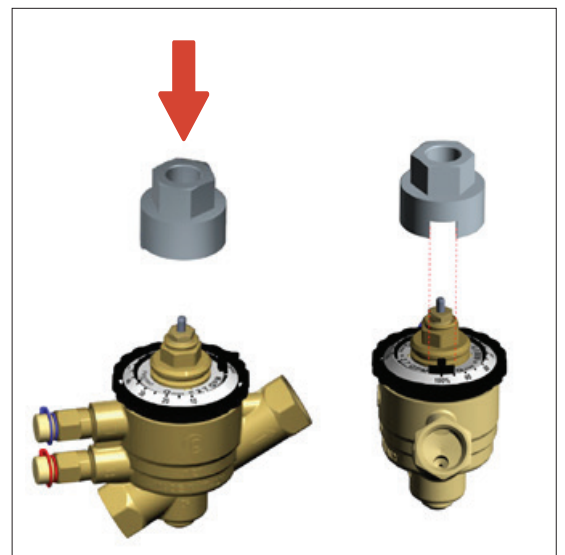

Step 3: using a 26mm spanner unscrew the headwork.

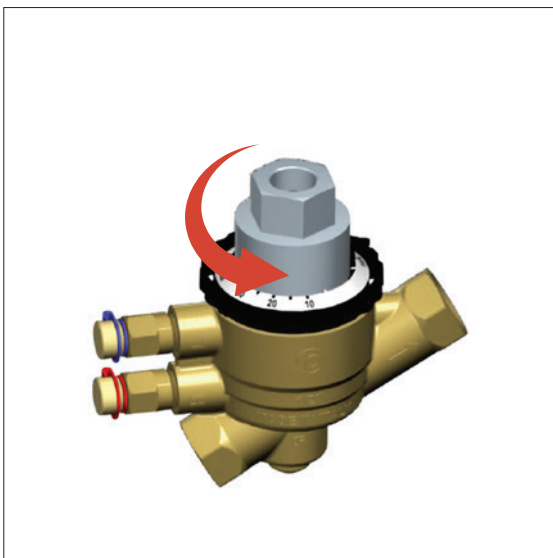

Step 4: remove the headwork.

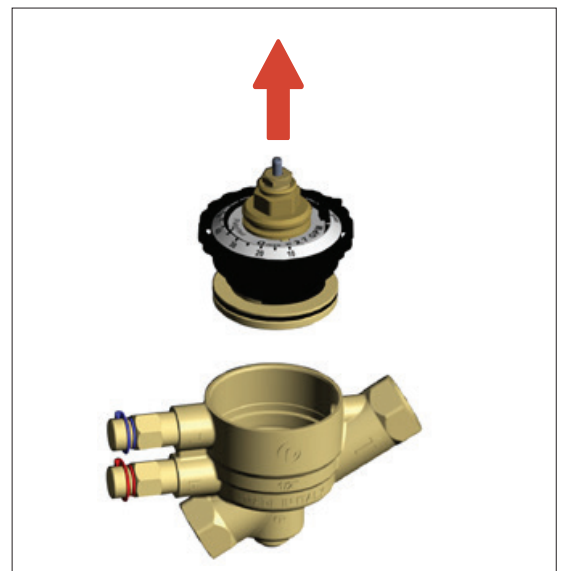

## TECHNICAL SPECIFICATION

Step 5: Insert the nose pliers through the center of the diaphragm

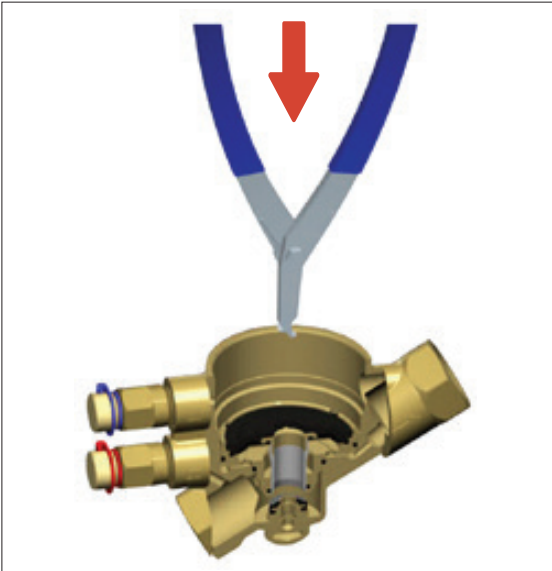

Step 6: open the plier and pull the diaphragm up out of the body

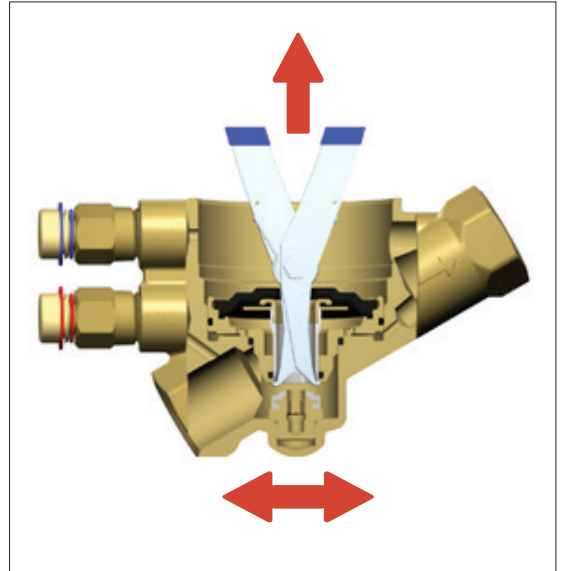

Step 7: Insert the new diaphragm 091D

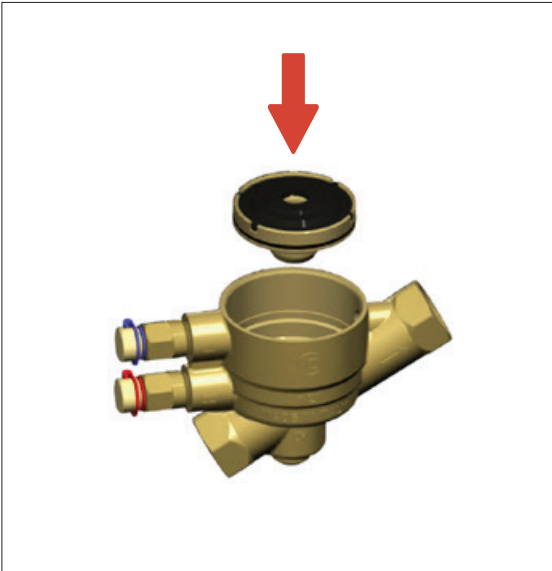

Step 8: Replace the headwork

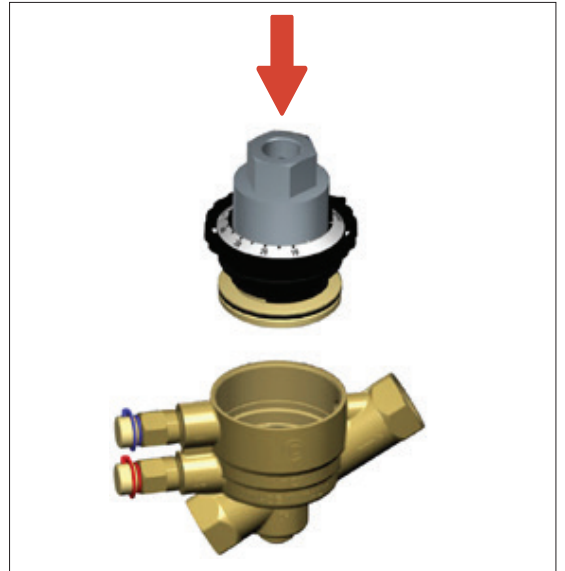

Step 9: Screw the headwork with 15/20 Nm torque reaching the initial position of the lock pin

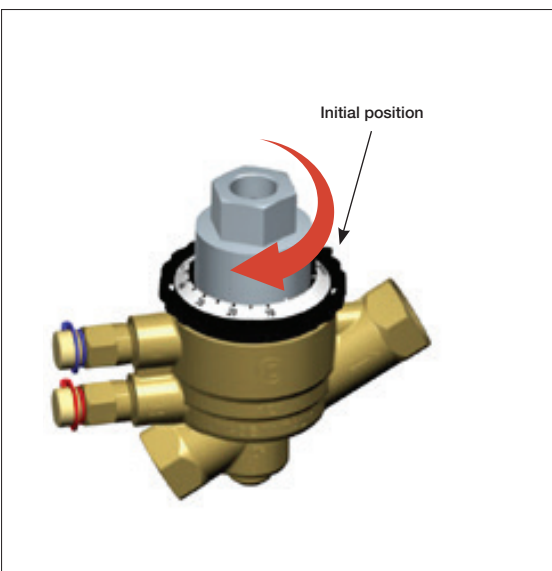

Step 10: remove the 26 mm adapter key and replace the actuator a adapter

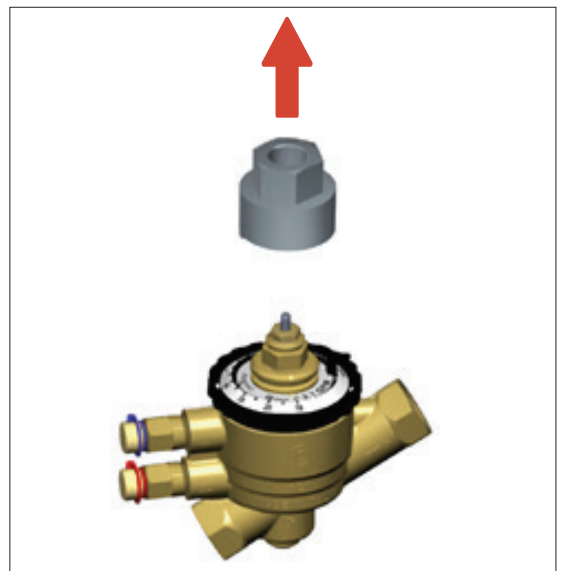

## EN Start-up curves and presetting

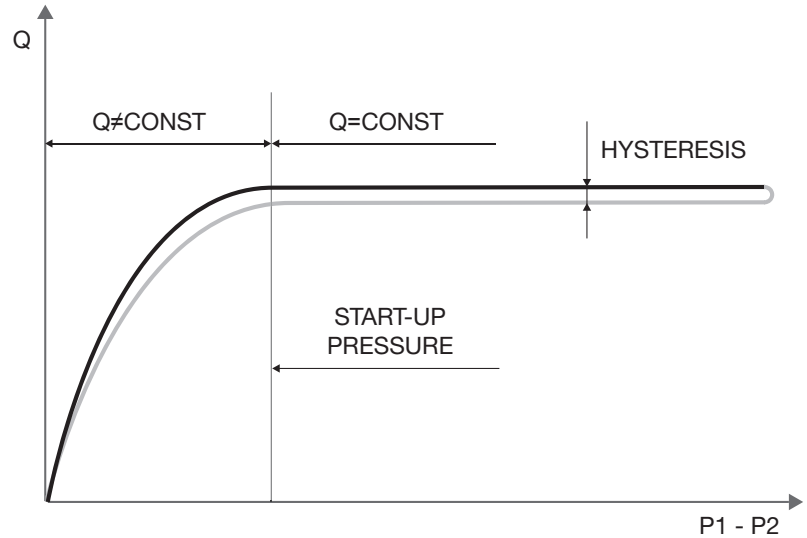
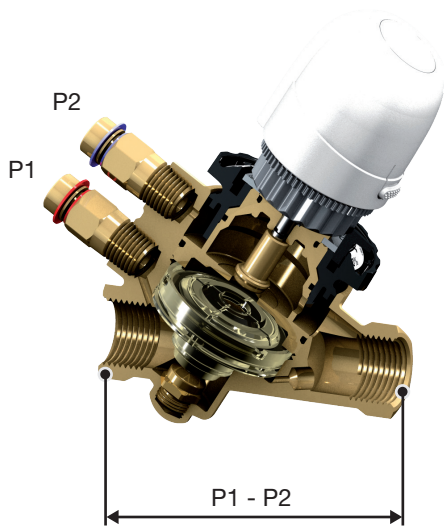

The example above shows a characteristic curve where start-up pressure, hysteresis and accuracy can be evaluated.

Using a differential pressure gauge to measure the pressure drop the valve absorbs, allows to check whether the valve is in the operating range (and, therefore, whether the flow is constant) by simply verifying that the measured value  $P1 - P2$  is higher than the start-up value.

If the  $\Delta P$  measured value is lower than the start-up value, then the valve works as a fixed orifice valve. Start-up value varies with flow setting of the valve, as shown by the example below:

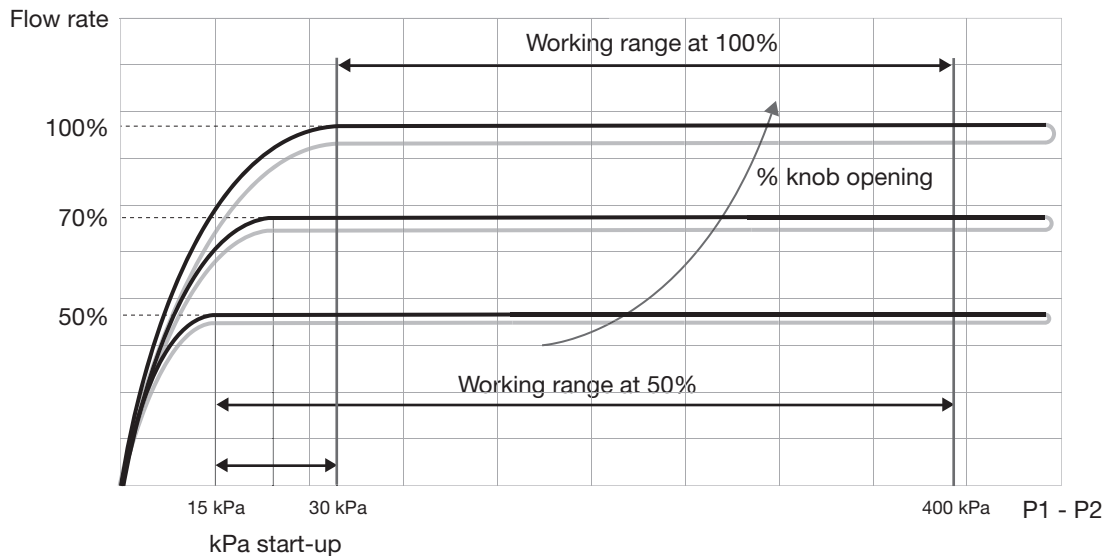

When the valve is set at 100% of nominal (maximum) flow, the curve begins to remain constant at 30 kPa, therefore the working range of the valve is  $30 \div 400$  kPa;

When the valve is set at 50% of nominal flow, the curve begins to remain constant at 15 kPa, therefore the working range of the valve is  $15 \div 400$  kPa.

The following diagrams show the start-up pressure at different presetting.



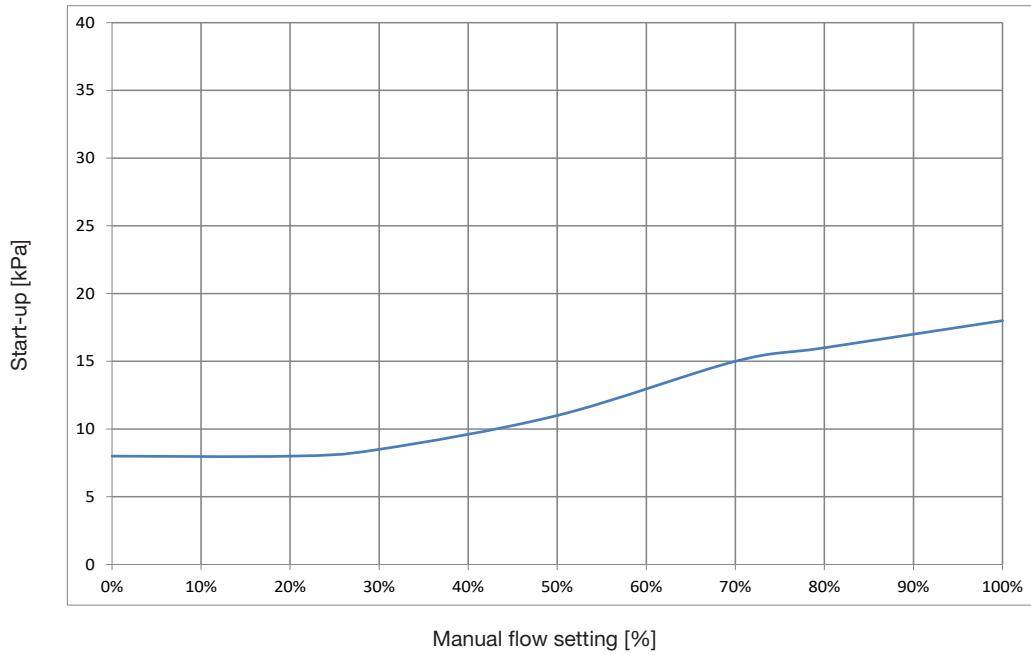

Valve model
91VL 1/2" - 150 l/h
91VL1 1/2" - 150 l/h

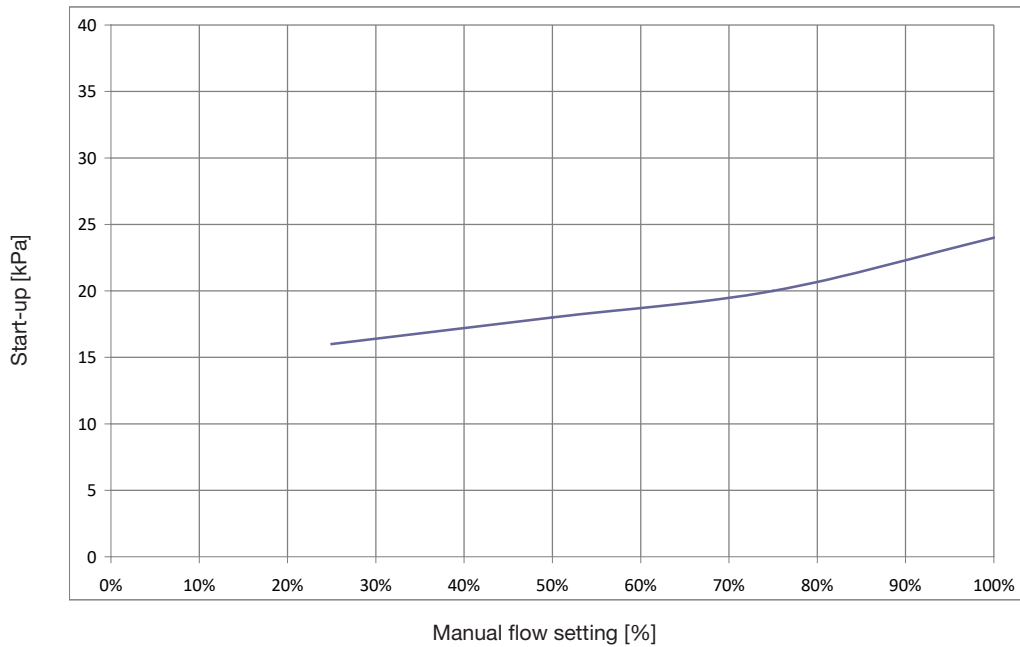

Valve model
91L 1/2" - 600 l/h
91L1 1/2" - 600 l/h

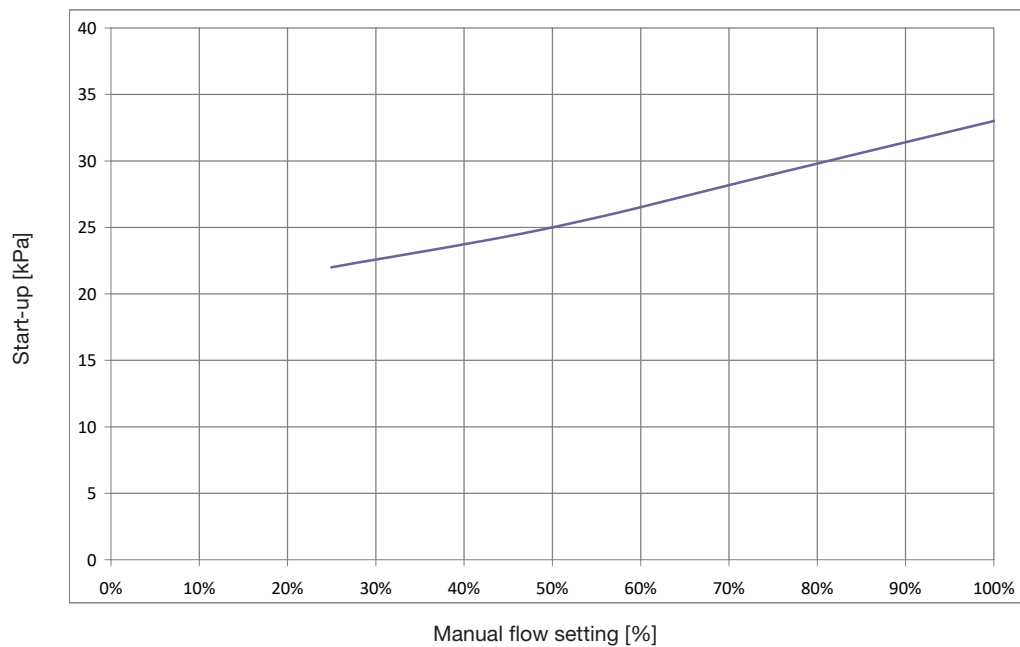

Valve model
91H 1/2" - 780 l/h
91H1 1/2" - 780 l/h



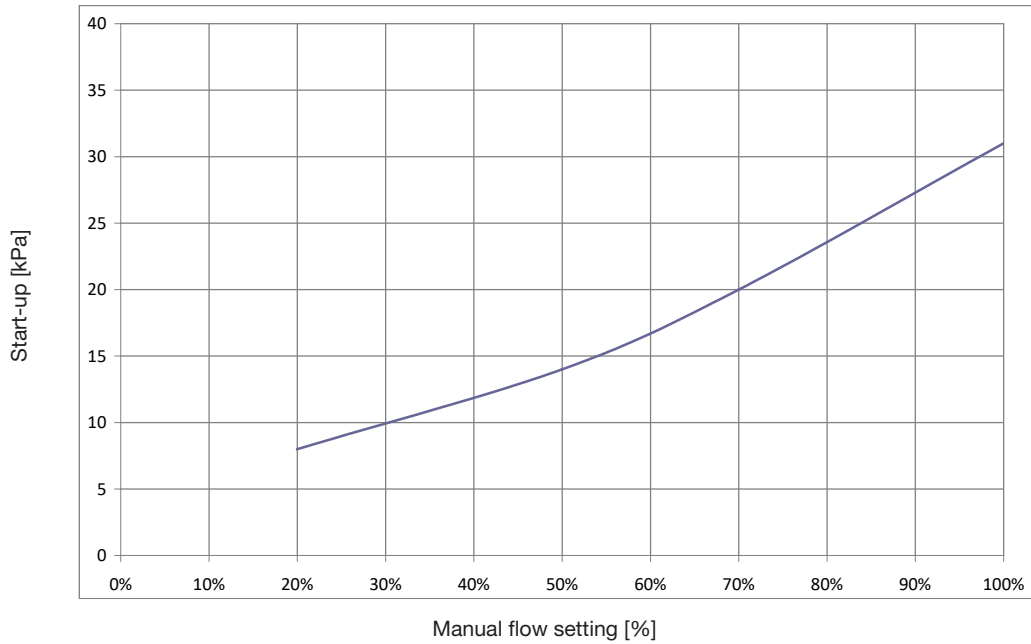

Valve model
91L 3/4" - 1000 l/h
91L1 3/4" - 1000 l/h

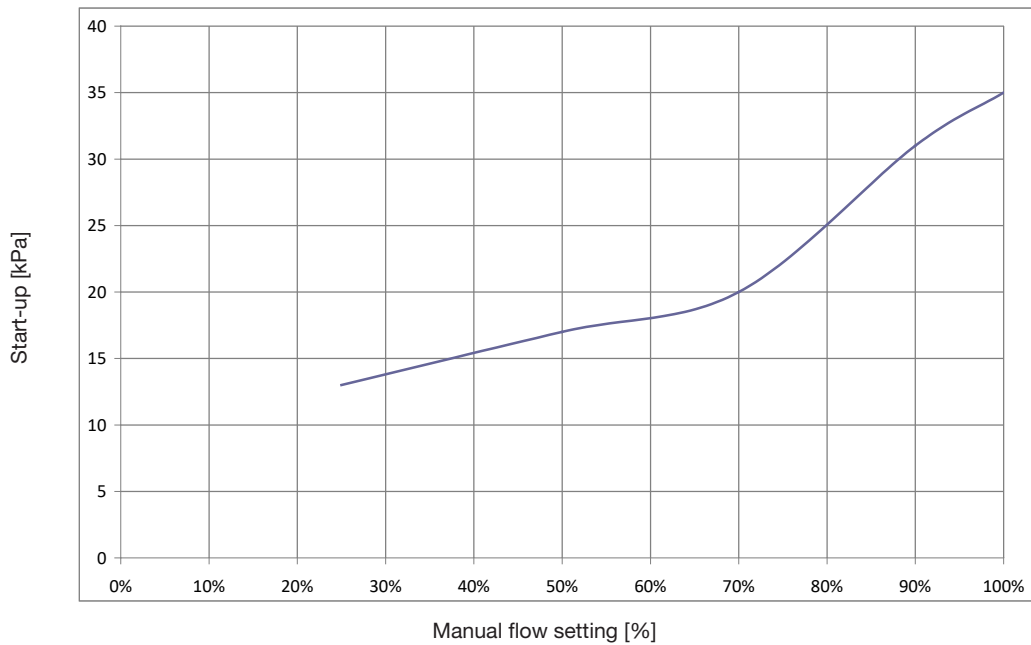

Valve model
91H 3/4" - 1500 l/h
91H1 3/4" - 1500 l/h
91H 1" - 1500 l/h
91H1 1" - 1500 l/h

Flow pre-setting 91 / 91-1 EvoPICV

Presetting %	91VL-91VL1 1/2"		91L-91L1 1/2"		91H-91H1 1/2"		91L-91L1 3/4"		91H-91H1 3/4"		91H-91H1 1"	
	Flow rate		Flow rate		Flow rate		Flow rate		Flow rate		Flow rate	
	l/h	l/s	l/h	l/s	l/h	l/s	l/h	l/s	l/h	l/s	l/h	l/s
100	150	0,042	600	0,167	780	0,217	1000	0,278	1500	0,417	1500	0,417
90	135	0,038	540	0,150	702	0,195	900	0,250	1350	0,375	1350	0,375
80	120	0,033	480	0,133	624	0,173	800	0,222	1200	0,333	1200	0,333
70	105	0,029	420	0,117	546	0,152	700	0,194	1050	0,292	1050	0,292
60	90	0,025	360	0,100	468	0,130	600	0,167	900	0,250	900	0,250
50	75	0,021	300	0,083	390	0,108	500	0,139	750	0,208	750	0,208
40	60	0,017	240	0,067	312	0,087	400	0,111	600	0,167	600	0,167
30	45	0,013	180	0,050	234	0,065	300	0,083	450	0,125	450	0,125
20	30	0,008	120	0,033	156	0,043	200	0,056	-	-	-	-
10	15	0,004	60	0,017	78	0,022	100	0,028	-	-	-	-



### EN Control curves

Operating on the position of the regulating valve control stem A will modify the valve Kv, hence the flow rate. The relation between Kv and stroke is shown in the graph below.

Typical control valve characteristic curves.\*

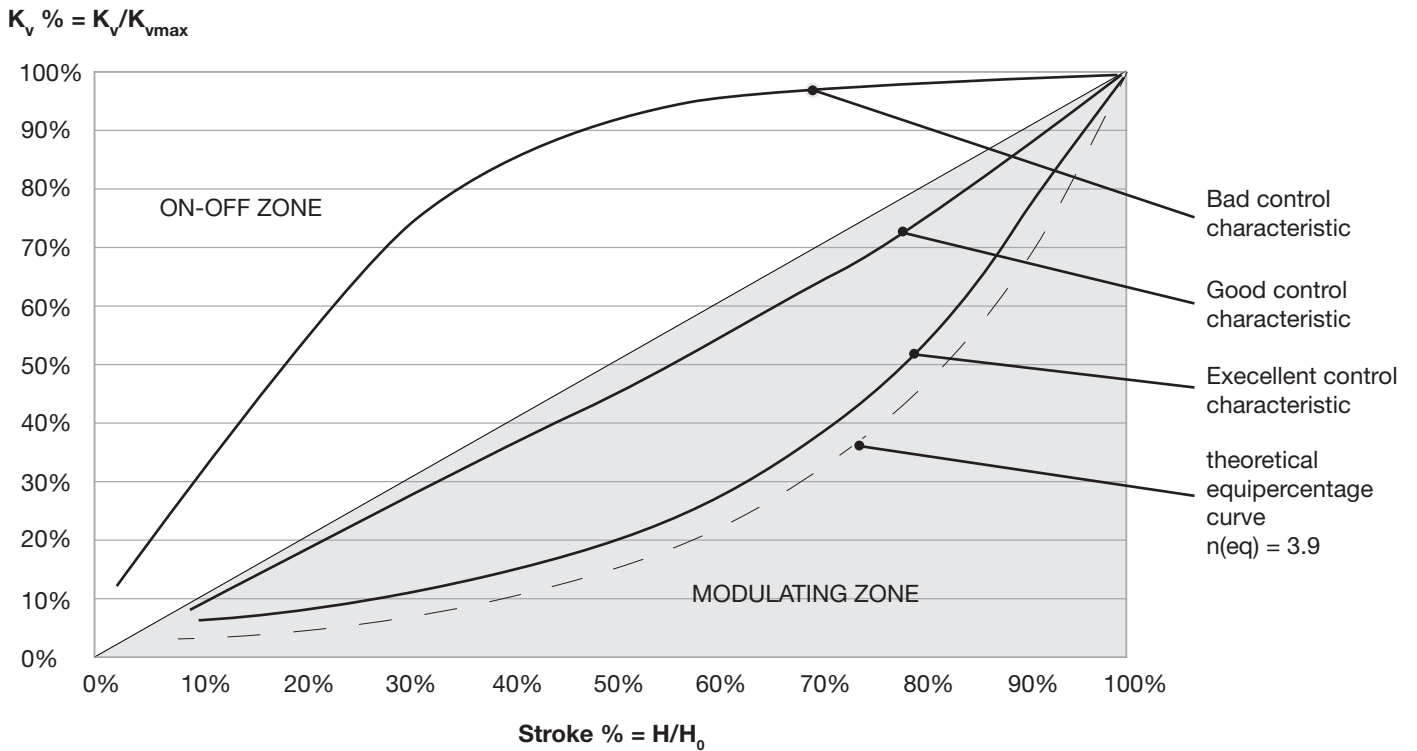

Combining the **EvoPICV** valve characteristic with heat exchanger results in a linear control system.

In the next page control curves of 91 and 91-1 are shown.

\* Control curve characteristic may change according to valve version.

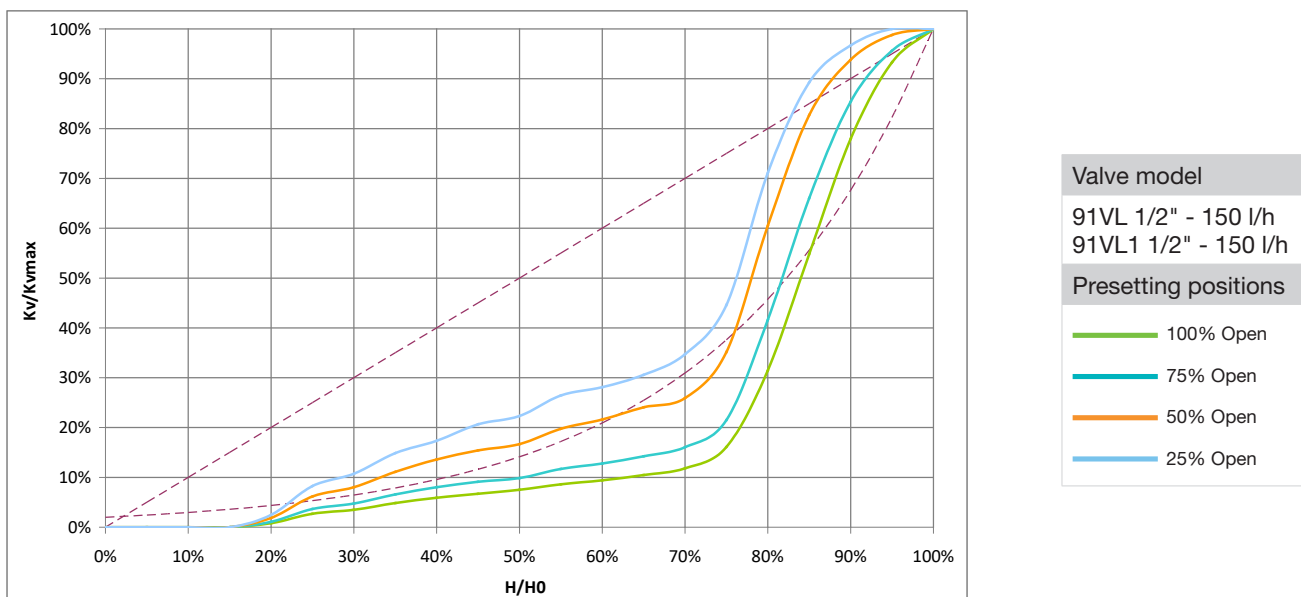

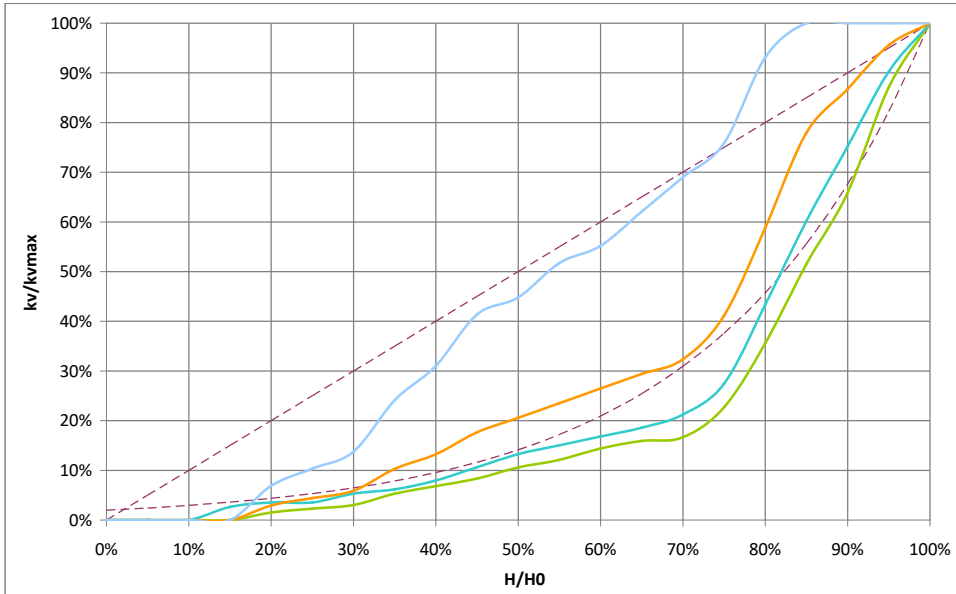

**Valve model**  
 91L 1/2" - 600 l/h  
 91L1 1/2" - 600 l/h

**Presetting positions**

- 100% Open
- 75% Open
- 50% Open
- 25% Open

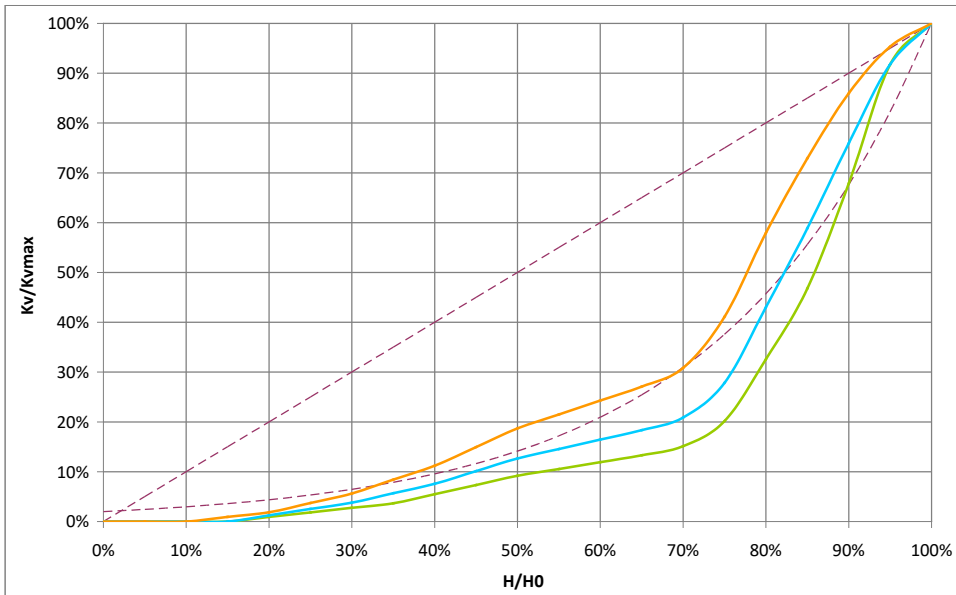

**Valve model**  
 91H 1/2" - 780 l/h  
 91H1 1/2" - 780 l/h

**Presetting positions**

- 100% Open
- 75% Open
- 50% Open

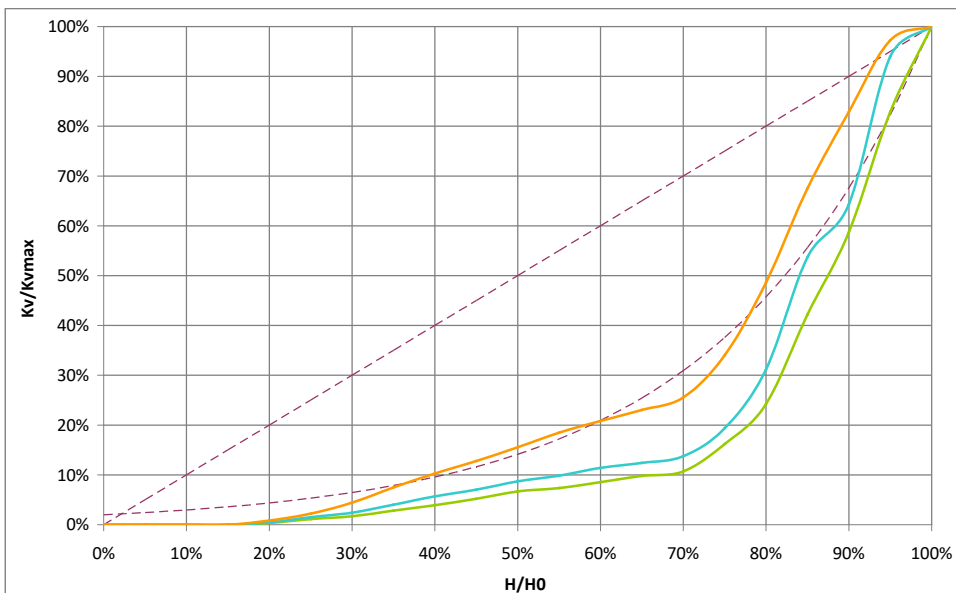

**Valve model**  
 91L 3/4" - 1000 l/h  
 91L1 3/4" - 1000 l/h

**Presetting positions**

- 100% Open
- 75% Open
- 50% Open



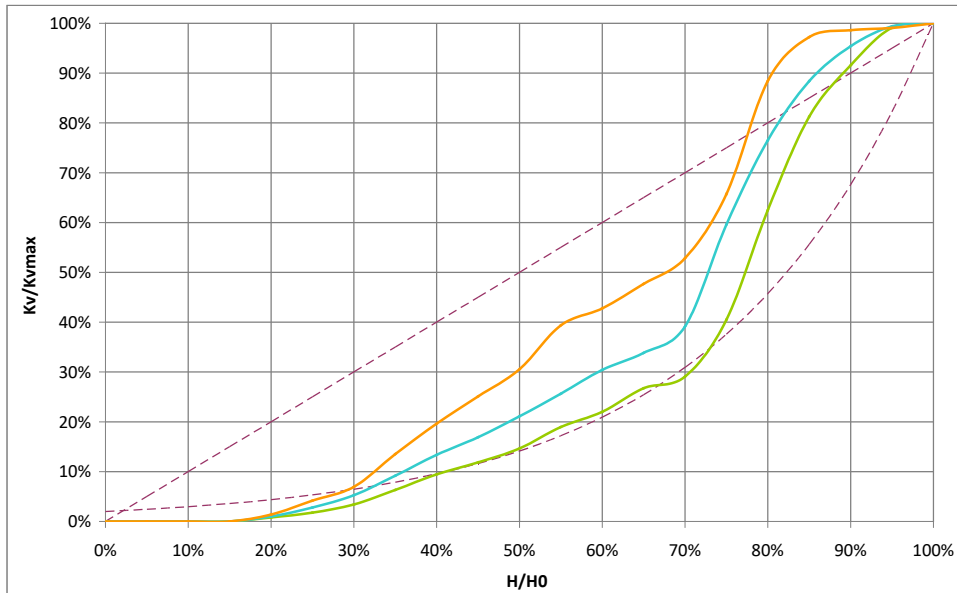

Valve model	
91H 3/4" - 1500 l/h	
91H1 3/4" - 1500 l/h	
91H 1" - 1500 l/h	
91H1 1" - 1500 l/h	
Presetting positions	
<span style="color: green;">—</span>	100% Open
<span style="color: cyan;">—</span>	75% Open
<span style="color: orange;">—</span>	50% Open

- H: current lift (opening) of the control valve; H varies from 0 to  $H_0$
- $H_0$ : maximum lift of the control valve;
- $K_v$ : valve flow factor at lift = H
- $K_{vmax}$ : valve flow factor at lift =  $H_0$

## EN Actuators

The table below shows actuator part numbers for different control types.

Type	Standard	Stroke	Adaptor
24v, 0-10v Proportional	VA7483	Self-detection	0A7010*
24v, 3 Point Floating	VA7481	6,3 mm	0A7010*
230v, 3 Point Floating	VA7481	6,3 mm	0A7010*
24v, 0-10v Proportional Thermic	A544P3	4 mm	VA64**
24v, ON-OFF Thermic, 2 wires	A544O2	4 mm	VA64**
24v, ON-OFF Thermic, 4 wires	A544O4	4 mm	VA64**
230v, ON-OFF Thermic, 2 wires	A542O2	4 mm	VA64**
230v, ON-OFF Thermic, 4 wires	A542O4	4 mm	VA64**
24v, 0-10v Proportional Fail Safe	VA7484	Self-detection	0A7010*

\* Adaptor not included      \*\* Adaptor included

Fratelli Pettinaroli is not liable for unauthorized use of actuator not shown in the table above. However, actuating force must not exceed 160 N. Available also VM060 (proportional electromechanical actuator with fail safe) with 76TE ring included.

## EN Accessories



### MDPS2

Digital differential manometer Bluetooth® for start-up test of PICV valves and flow rate measurement of Terminator balancing valves and Venturi devices. To be used with specific app installed on a smartphone.



**MDP**

Digital differential manometer differential pressure measurement.



**091SETP**

Kit for diaphragm replacement of EvoPICV 91 / 91-1 valves.



**INSULATING CASES**

Class 1 fire rated insulating case for PICV. For heating and cooling installations.

**091IHV:** case for heating, closure by Velcro®. Size has to be specified.

**091IHB:** case for heating, closure by double-sided tape. Size has to be specified.

**091ICV:** case for cooling, closure by Velcro®. Size has to be specified.

**091ICB:** case for cooling, closure by double-sided tape. Size has to be specified.

Cases for heating let the headwork and the actuator uncover whereas those for cooling cover the actuator too (all those in the range). Insulation sheel has a thin external layer made of 80 kg/m<sup>3</sup> density polyethylene cross linked foam and a thicker internal layer made of 29 kg/m<sup>3</sup> density polyethylene cross linked foam. Total thickness: 20 mm.

Feature	Insulation case	
Density [kg/m <sup>3</sup> ]	29	80
Operating temperature range [°C]	-60 / +90	-60 / +90
Thermal conductivity [W/mK]	0.040	0.049
Thickness [mm]	18	2

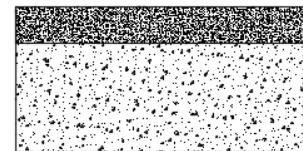

Cross section insulation sheel

**EN Generals**

Pettinaroli does not accept any liability for improper or wrong use of this product.

Always protect the pressure regulator by using strainers upstream of the valve and, in any case, make sure water quality complies with UNI 8065 standard. Fratelli Pettinaroli suggests to follow recommendations of VDI 2035/1 too. Maximum suggested content (total) content of Iron and Copper should be: Fe < 0.5 mg/kg and Cu < 0.1 mg/kg.

Furthermore, maximum iron oxide in the water passing through control valve (PICV) must not exceed 25 mg/Kg (25 ppm).

To ensure the main pipework is cleaned appropriately, flushing by-passes should be used without flushing through the pressure regulator of the PICV thereby preventing dirt that might clog the valve.

\*The product color may be different with the actual product color due to printing procedure. \*The appearance and specifications may change with no prior notice for improvement.  
\*The data and photo should not be used without permission of the copyright holder.



**Fratelli Pettinaroli Spa**

Via Pianelli, 38 - 28017 San Maurizio d'Opaglio (NO) - Italy  
Tel. +39 0322 96217 - +39 0322 96545 - Fax +39 0322 96546  
info@pettinaroli.com - www.pettinaroli.com

