



DESCRIPTION

BF1SE

Shut-off LUG butterfly valve for HVAC (heating and cooling), water treatment and distribution (no drinking water). Ductile iron body. Integrated support ISO 5211 for actuators assembling. Lever included.

DIMENSIONS

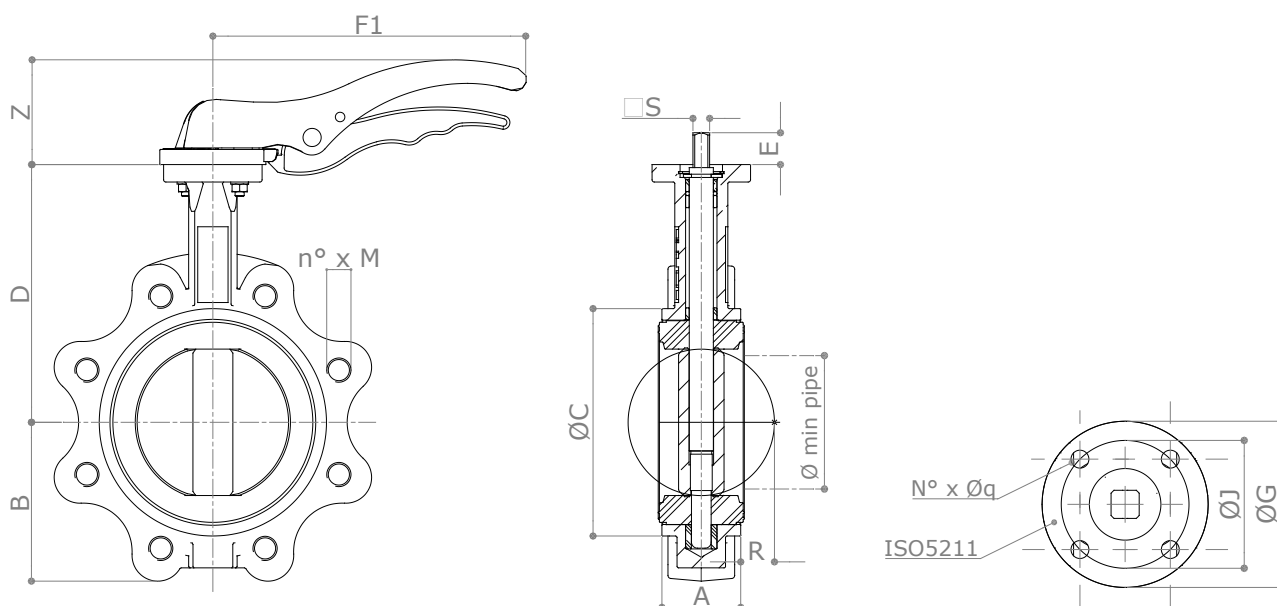

DN	25	32	40	50	65	80	100	125	150	200	250
A	33	33	33	43	46	46	52	56	56	60	68
ØC	65	73	82	89	102	118	150	174	205	260	318
D	104	110	116	126	136	150	170	180	200	230	266
B	51	56	63	62	69	90	106	1196	131	166	202
F1	192	192	170	170	170	206	206	285	285	400	530
Z	68	68	50	50	50	69	69	90	90	72	72
R	-	1	5	5	9	17	26	34	50	71	91
D min pipe	-	12	27	31	45	65	90	110	146	194	241
n x M	4 x M12	4 x M16	4 x M16	4 x M16	4 x M16	8 x M16	8 x M16	8 x M16	8 x M20	12 x M20	12 x M24
ISO 5211	F05	F05	F05	F05	F05	F05	F05	F07	F07	F10	F12
G	65	65	65	65	65	65	65	90	90	125	150
J	50	50	50	50	50	50	50	70	70	102	125
n x q	4 x 7	4 x 7	4 x 7	4 x 7	4 x 7	4 x 7	4 x 7	4 x 9	4 x 9	4 x 11	4 x 12
S	7	7	9	9	9	11	11	14	14	17	27
E	32	32	21	21	21	21	21	27	27	27	27
PN	16	16	16	16	16	16	16	16	16	16	16
Weight [kg]	2.6	2.6	2.3	3.2	4.1	5.4	6.7	9.6	10.8	21.1	32.7

Dimensions in mm

From DN300 to DN400 available on request (lever not available, manually actuated by gear box, not included).

MATERIALS

Body	Ductile iron EN GJS 400-15
Disc	Stainless steel AISI316
Stem	Stainless steel AISI 420
Liner	EPDM
Bushing	PTFE
Washer	Galvanized carbon steel
Circlip ISO 3075	Spring steel
O-Rings	FKM
Lever	Aluminium (DN25-DN150) – Ductile iron EN GJS 400-15 (DN200-DN250)

APPROVALS



DN65 to DN200 – beyond DN200, the valves have not been verified according to 2014/68/EU Directive. In all EU countries, the required safety rules are not fulfilled.

ACCESSORIES

Gear box

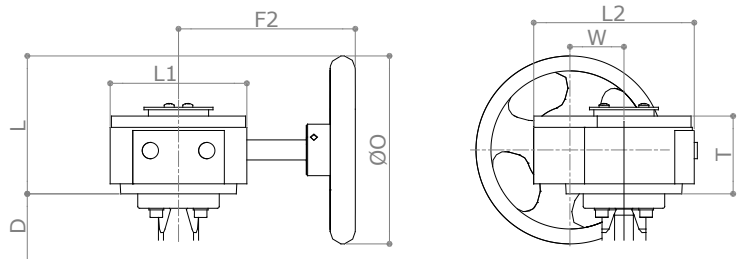

DN	25	32	40	50	65	80	100	125	150	200	250
L	102.5	102.5	102.5	102.5	102.5	102.5	102.5	102.5	102.5	190	190
L1	110	110	110	110	110	110	110	110	110	155	170
L2	130	130	130	130	130	130	130	130	130	176	200
W	45	45	45	45	45	45	45	45	45	63	81
T	65	65	65	65	65	65	65	65	65	78	80
ØO	150	150	150	150	150	150	150	150	150	300	300
D	<i>See table in section "DIMENSIONS"</i>										

PRESSURE DROP DIAGRAM

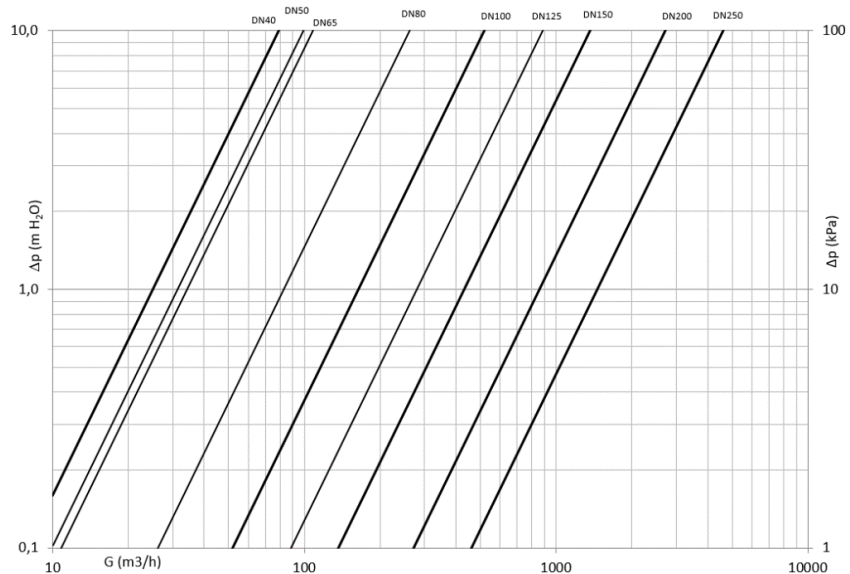

Kv	DN	40	50	65	80	100	125	150	200	250
Opening angle	10°	0.04	0.05	0.09	0.17	0.26	0.43	0.69	2.6	2.6
	20°	2.1	2.6	3.8	7.8	15	25	39	52	130
	30°	4.8	6	14	16	31	53	82	142	276
	40°	10	13	33	34	67	115	177	250	599
	50°	19	23	53	60	120	205	316	450	1068
	60°	30	38	75	100	199	339	522	713	1768
	70°	48	60	98	158	314	535	827	1122	2798
	80°	73	91	108	237	471	803	1241	1723	4196
	90°	79	99	108	261	518	883	1364	2716	4611

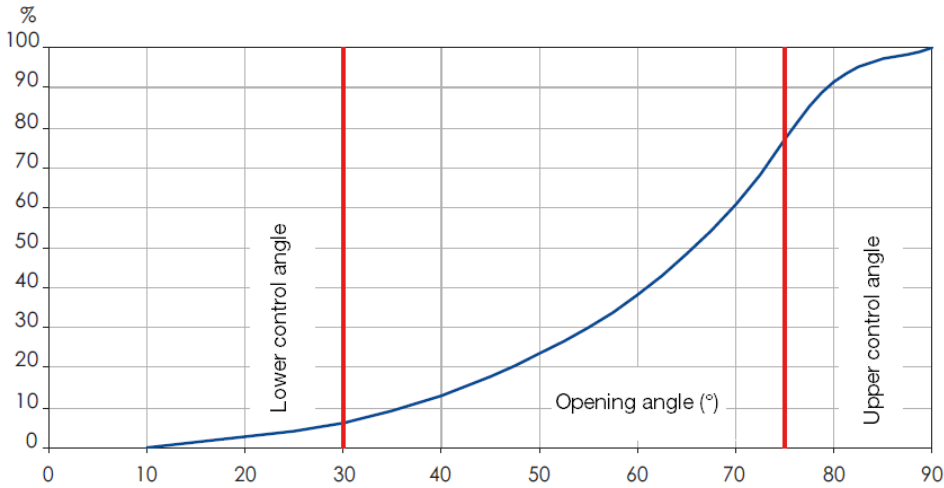

TEMPERATURE / PRESSURE DIAGRAM

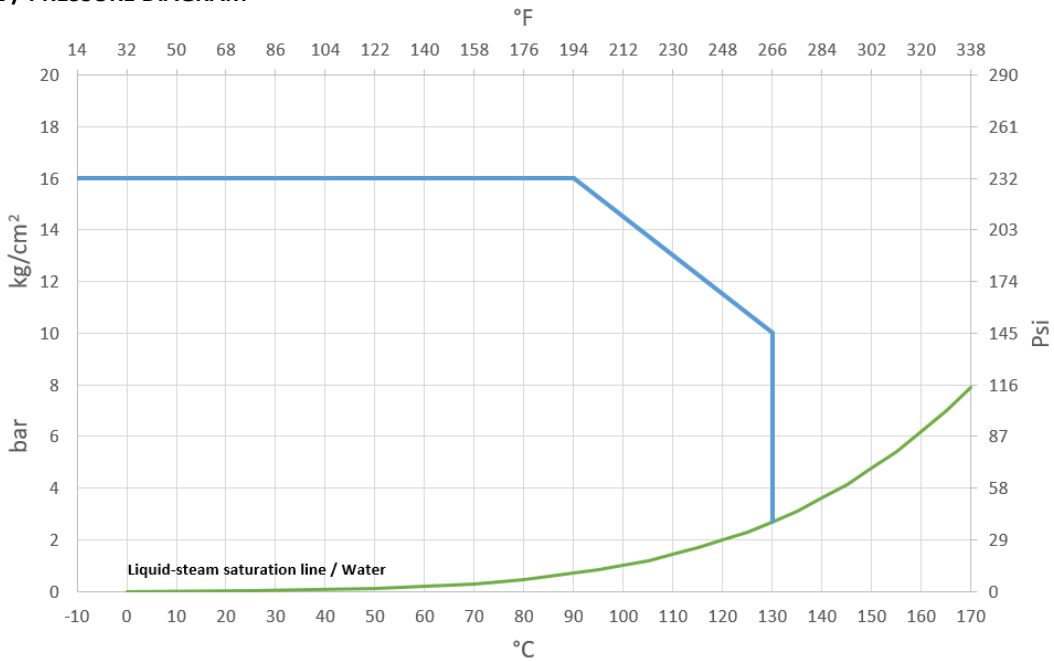

RECOMMENDED WORKING TEMPERATURE/PRESSURE LIMITS

Temperature	Min°C	Max°C – Continuous	Max°C - Peak
EPDM	-10	120	130

Nominal pressure	Between flanges	End line	Fluids
DN25-DN300	16 bar	10 bar	Water / water+glycol 30%
DN350-DN400	10 bar	6 bar	

OPERATING TORQUE (Nm)

DN	25	32	40	50	65	80	100	125	150	200	250
DP 3 bar	2.9	4.7	7.8	11.3	17	23	33	48	68	120	189
DP 6 bar	3.1	5.1	8.4	12	18	25	36	56	78	134	212
DP 10 bar	3.3	5.4	8.8	13	20	26	40	61	88	148	234
DP 16 bar	3.4	5.7	9.2	13	21	28	44	68	99	162	257

INSTALLATION

Handle with care.

Do not weld the flanges to the piping after installing the valve.

Water hammers might cause damage and ruptures. Inclination, twisting and misalignments of the piping may cause the valve to stress, once installed. Use of elastic joints is recommended in order to reduce these effects as much as possible. The disc must be partially open (Fig. 1).

The stem has a machined notch N (Fig. 2), which indicates the position of the disc; consider this indication, in order to mount the levers and actuators correctly.

The valve can be installed with the stem axis in horizontal or vertical position. In case the fluid contains suspended solid particles (for example sand, impurities, etc.) or particles that may leave deposits, it is recommend the horizontal installation of the valve, and in such a way that the bottom end of the disc opens in the direction of flow F (Fig. 3).

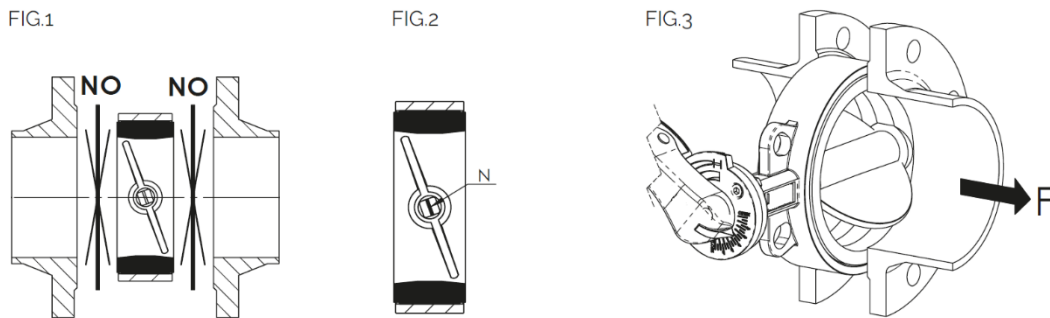

The valve allows the dismantling of the pipes downstream, for pressures below 6 bar. For end of line installation:

- pressure > 6 bar: counter flange **MUST** be installed
- pressure < 6 bar: installation of a counter flange is recommended.

Verify maximum working pressure and limits of use under section “Nominal pressure”.

Place the valve between two flanges. While placing the valve, ensure there is sufficient space in order not to damage the rubber. Do not mount seals between valve and flanges. Carefully clean the contact surface. Do not install the butterfly valve in direct contact with a rubber surface (for example, expansion joints); the best installation is contact between rubber liner and metal (Fig. 4).

In order to ensure correct operation, the internal diameter of the pipe must be larger than the value indicated in dimension section. Do not weld the flanges to the tube if the valve has already been installed. Use flanges listed in the specific table. As far as possible, avoid flat welding flanges (EN 1092 01 type); if these flanges are used, ensure perfect centring between the flange and valve, and be sure to weld exactly edgewise to the flange.

Do not leave sharp edges on the pipe: they may cause damage to the rubber surface of the valve (Fig. 5).

Tighten the bolts crosswise and progressively, in order to distribute the pressure equally before the valve body and flanges touch each other (Fig. 6). Check that the screws have the correct length, in order to allow complete compression of the lining rubber.

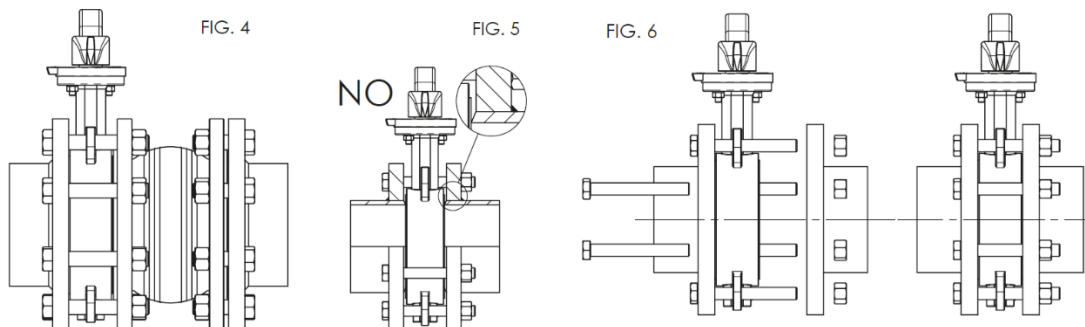

Turbulences of the fluid might increase erosion and reduce the life-cycle of the valve. Install the valve at a distance of at least 1 x DN upstream and 2-3 x DN downstream, away from fittings or bends.

In the open position, the valve is larger than the nominal Face to Face value. So check that no other components of the piping interfere or create damage or malfunction (Fig. 7A). If they do, a spacer should be inserted to let the valve operating correctly (Fig. 7B).

FIG. 7A

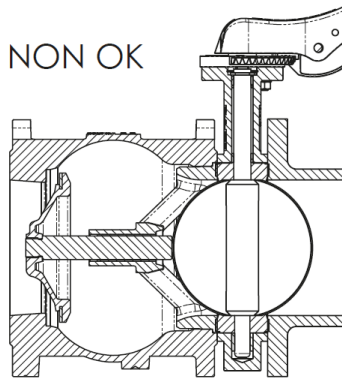
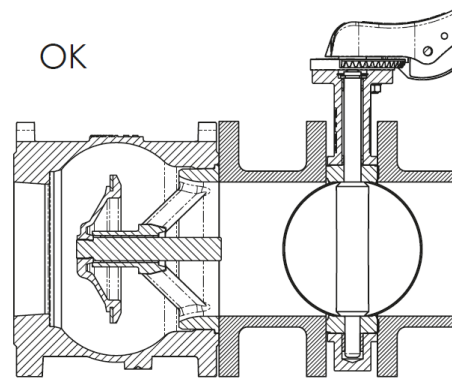

FIG. 7B



FLANGES CHART

Standard	Type	
EN 1092-2 PN 10 /16	Type 11	Weld neck
	Type 21	Integral
	Type 02 + 35	Loose plate with weld ring neck
	Type 02 + 36	Loose plate with pressed collar
	Type 04 + 34	Loose plate with weld ring neck collar

BOLT LENGTH CALCULATION (NOT INCLUDED)

$$L_{max} \leq T+W+P$$

L_{max} : max length of screws

P : max implantation depth

T : flange thickness (flange given by the user)

W : washer thickness at head screw

$H > L-T$: min thread length

DN	25	32	40	50	65	80	100	125	150	200	250
A	33	33	33	43	46	46	52	56	56	60	68
P	14	14	14	18	20	20	22	22	25	27	30
W (DIN125 / ISO7089)	2.5	3	3	3	3	3	3	3	3	3	4

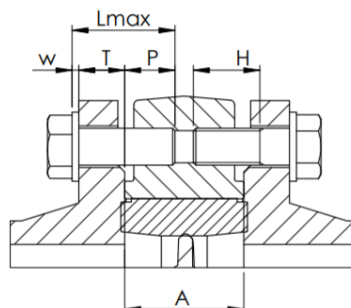

Suggested length in case the valve is installed between steel flanges EN1092-1 type 11 PN16 and PN10, with DIN125/ISO7089 washers. Always verify the screw length according to installation requirements.

DN	25	32	40	50	65	80	100	125	150	200	250
M x L	M12x30	M16x30	M16x35	M16x35	M16x40	M16x40	M16x45	M16x45	M20x50	M20x50	M24x60