

DESCRIPTION

102H – K102H/1 – K102H/2

PA66 (GF30) magnetic dirt separator with strainer for horizontal installation under the boiler, suitable for installations in fairly confined spaces. Equipped with:

- Inspectable filter (700 µm).
- Adjustable drain for maintenance operations.
- Removable magnet for maintenance operations.



APPLICATION FIELD

The EvoMAGic 102H series magnetic dirt separator is used as a separator for impurities (magnetic and non-magnetic) that are often found in domestic heating systems; the presence of a removable magnet and an adjustable drain allows to discharge these impurities quickly and effectively during maintenance operations.

The specific configuration of the EvoMAGic 102H series magnetic dirt separator allows installation under wall boilers (under-boiler) even in confined spaces (typical situations that occur when the dirt separator is added to existing systems).

Different versions are available:

- 102H – magnetic dirt separator with strainer.
- K102H/1 – kit magnetic dirt separator with ball valve 52MET/1 3/4" M x 3/4" F flat end swivel nut and union 1007WFF 3/4" F x 3/4" F flat end swivel nut
- K102H/2 – kit magnetic dirt separator with 2 nos ball valve 52MET/1 3/4" M x 3/4" F flat end swivel nut.

DIMENSIONS

102H

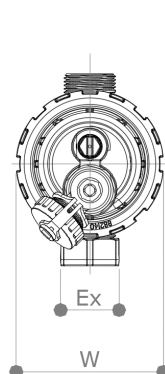
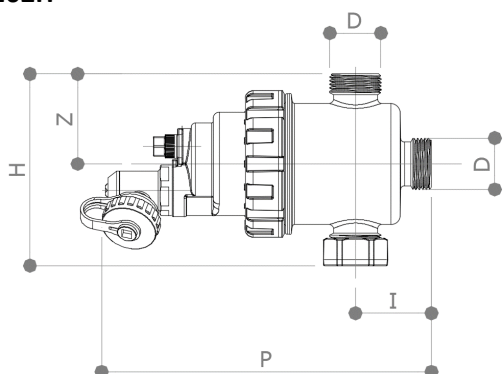

D	=	3/4" M ISO228 flat end
P	=	167 mm
H	=	98 mm
W	=	76 mm
Z	=	46 mm
I	=	39 mm
Ex	=	30 mm
Weight	=	338 g

K102H/1

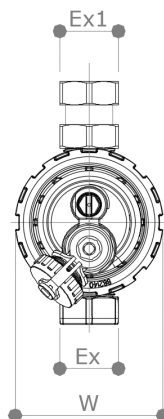
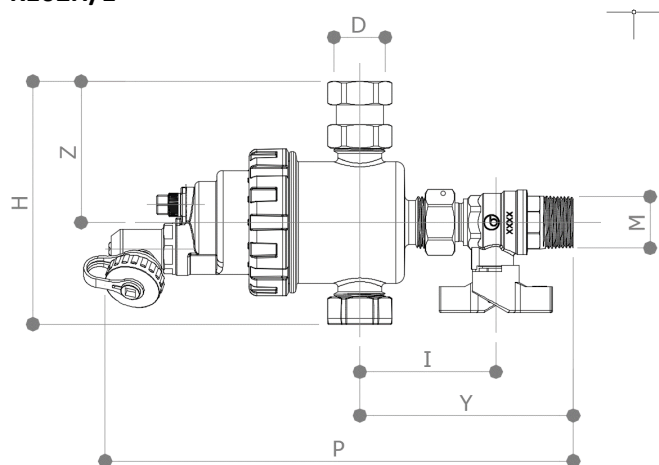

D	=	3/4" F ISO228 flat end
M	=	3/4" M
P	=	238 mm
H	=	124 mm
W	=	76 mm
Z	=	72 mm
I	=	70 mm
Ex	=	30 mm
Ex1	=	30 mm
Weight	=	680 g

K102H/2

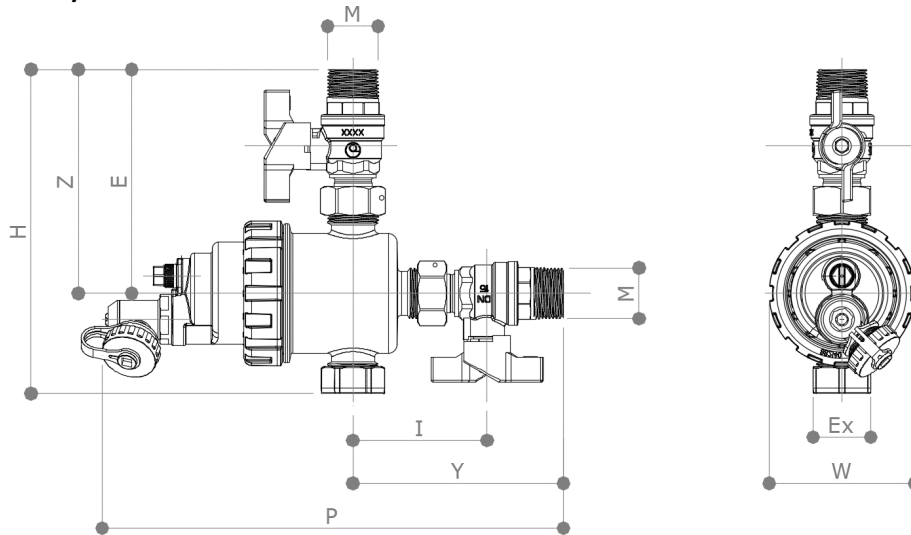

M	=	3/4" M	
P	=	238	mm
H	=	168	mm
W	=	76	mm
Z	=	116	mm
I	=	70	mm
E	=	76	mm
Y	=	109	mm
Ex	=	30	mm
Weight	=	851	g

COMPONENTS AND MATERIAL

Body	PA66 (GF30)
Internal flow diverter	POM
Magnet holder	POM
Holding nut	POM
Bottom body	PA66 (GF30)
Cap	PA66 (GF30)
Drain	CW617N Nickel plated
Union (K102H/1)	EN12163 - CW617N
Ball valves (K102H/1 and K102H/2)	EN12163 - CW617N
Strainer	AISI 304
Washers and O-Ring	EPDM

FEATURES

Medium	Water (glycol max.30 %)
Max working temperature	90°C
Max working pressure	4 bar
Magnet	REN35 11.800-12.400 Gs
Strainer mesh	700 µm

OPERATING PRINCIPAL

Thanks to the magnet and the strainer, the EvoMAGic 102H series magnetic dirt separator can capture and collect the suspended debris (magnetic and non-magnetic) carried around by the flow. A specific lamellar diverter conveys the flow inside a strainer delimited; the magnetic field generated by the removable magnet acts within it. The magnetic impurities are caught thanks to the magnet, whereas the non-magnetic particles are blocked by the strainer and tends to settle in the bottom body (calm chamber) of the dirt separator. Once the strainer is crossed, the cleaned flow rate moves on towards the generator (boiler, chiller or heat pump).



PRESSURE DROP DIAGRAM

The diagram shown beside represents the trend of the pressure drops generated by the dirt separator according to the flow rate across it. According to design rules, water speed into pipes should not exceed 1,2-1,3 m/s. This means that the suggested max flow rate across the dirt separator should be around 1,15/1,20 m³/h (1150-1200 l/h).

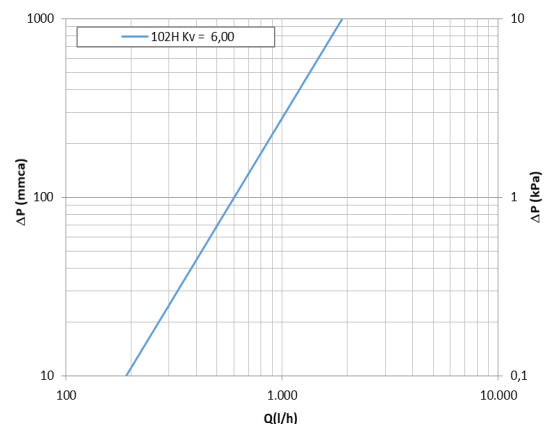

INSTALLATION

The EvoMAGic 102H series magnetic dirt separator has been specifically developed for "under-boiler" installation, where the available clear space is usually limited. It must be installed on the **RETURN** pipes (just upstream the heat generator) in order for catching and collecting all the magnetic and non-magnetic particles. Flow direction must be observed to ensure the proper operation of the product.

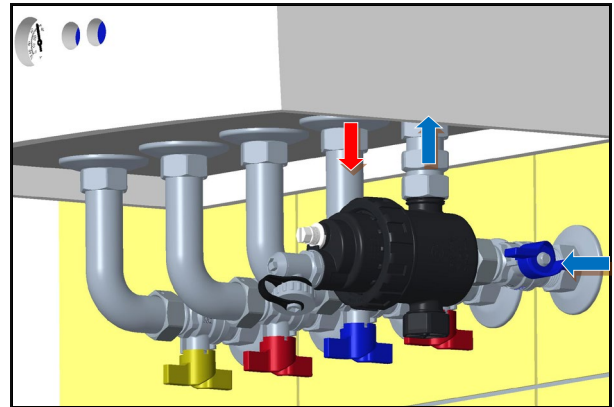

CLEANING AND MAINTENANCE

Particles removal

Removal of a-magnetic particles (captured by the strainer) and magnetic particles (attracted by the magnet) can be carried out with the system running.

1. Remove the magnet by turning 90° counter clockwise the magnet holder to loosen it. Use a screwdriver or a 10 mm socket wrench;
2. open the orientable drain through the square key on the drain cap. Before opening the drain, connect a hose with 3/4" hose connection.

NB: be sure that the pressure of the system never falls under minimum operating set while steps 1 and 2 are carried on. Therefore, the technician must know all needed operations (according to generator maintenance manual) in order to keep the pressure constant.

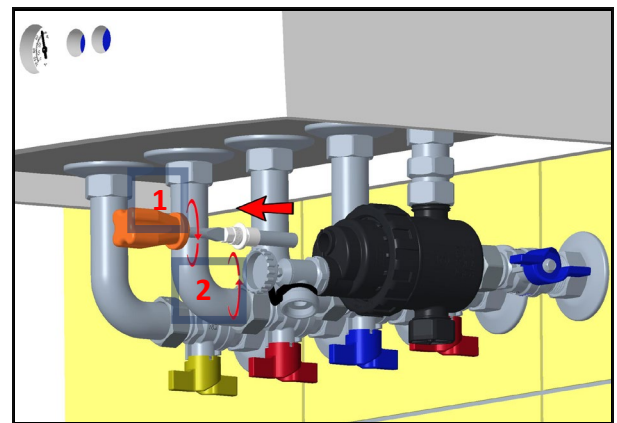

Removal and cleaning of the strainer

This operation **MUST** be carried out with the system OFF. Firstly, close the valves upstream and downstream the dirt separator: always minimize the water leakage.

Through the provided key, loosen the intermediate holding nut and remove the bottom body. Then, pull the strainer out and clean it with fresh water; if required, replace it. Finally, re-assemble everything. Care must be taken pushing the strainer in the upper body of the dirt separator.

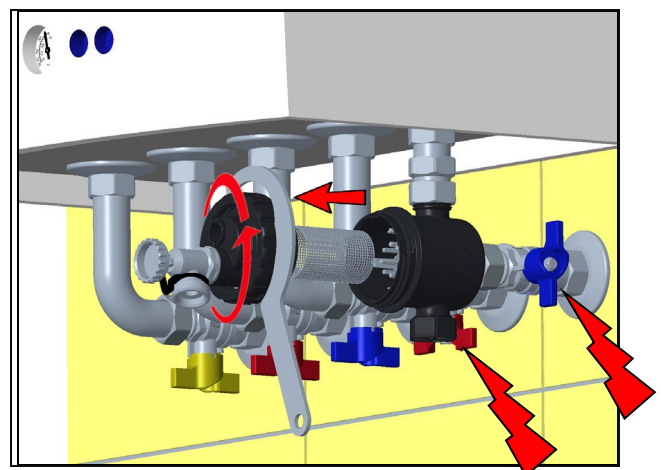

WARNING

The EvoMAGic 102H series magnetic dirt separator has a powerful magnet. It generates strong magnetic fields inside the device. Pacemaker holders are recommended to keep at a safe distance during operation and maintenance. Pay attention when using electronic devices near the magnet: performances can be affected by the magnetic field.

The plastic cap sealing the unused outlet of the EvoMAGic 102H series magnetic dirt separator must not be removed for any reason, including cleaning and maintenance operations.

ACCESSORIES

52MET/1: ball valve $\frac{3}{4}$ "M x $\frac{3}{4}$ "F flat end swivel nut.



52MET: ball valve $\frac{3}{4}$ "F x $\frac{3}{4}$ "F flat end swivel nut.

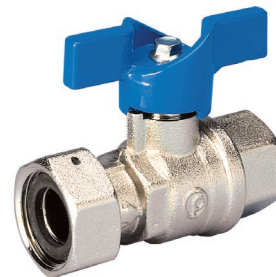

1007WFF: union $\frac{3}{4}$ "F flat end x $\frac{3}{4}$ "F flat end.

